



—
INSTALLATION GUIDE

HVC-C 100/150 E-Bus Charger

Installation Guide for NA products

Version 0.1



Notice

This document contains information about one or more ABB products and may include a description of or a reference to one or more standards that may be generally relevant to the ABB products. The presence of any such description of a standard or reference to a standard is not a representation that all of the ABB products referenced in this document support all of the features of the described or referenced standard. In order to determine the specific features supported by a particular ABB product, the reader should consult the product specifications for the particular ABB product.

ABB may have one or more patents or pending patent applications protecting the intellectual property in the ABB products described in this document.

The information in this document is subject to change without notice and should not be construed as a commitment by ABB. ABB assumes no responsibility for any errors that may appear in this document.

In no event shall ABB be liable for direct, indirect, special, incidental or consequential damages of any nature or kind arising from the use of this document, nor shall ABB be liable for incidental or consequential damages arising from use of any software or hardware described in this document.

This document is originally written in English. Other language versions are a translation of the original document and ABB cannot be held liable for errors in the translation.

This document and parts thereof must not be reproduced or copied without written permission from ABB, and the contents there of must not be imparted to a third party nor used for any unauthorized purpose.

Copyrights

All rights to copyrights, registered trademarks, and trademarks reside with their respective owners.

Copyright © 2019 ABB.

All rights reserved.

Table of Contents

1. Introduction	8
1.1. Preface	8
1.2. Intended document users	8
1.3. Signs	8
1.4. Safety regulations	9
1.4.1. Owner responsibilities	9
1.4.2. Tilting and handling	10
1.4.3. Electric hazards	11
1.4.4. Installation safety	11
1.5. Environment and disposal of waste	12
1.6. Contact information	13
2. Description of the product	14
2.1. Overview of the system	14
2.1.1. Standard HVC-C 100 E-Bus Charger with one Depot Charge Box	14
2.1.2. Standard HVC-C 100 E-Bus Charger with two or three Depot Charge Boxes	15
2.1.3. Standard HVC-C 150 E-Bus Charger with one Depot Charge Box	15
2.1.4. Standard HVC-C 150 E-Bus Charger with two or three Depot Charge Boxes	15
2.1.5. HVC Power Cabinet	16
2.1.6. Depot Charge Box	17
2.2. Accessories	18
2.2.1. Foundation for Power Cabinet	18
2.2.2. Pedestal for Depot Charge Box	19
2.2.3. Foundation for pedestal	19
2.2.4. Wall-mounting brackets for safe wall fixing	20
2.2.5. Communication glass fiber cable	20
2.3. Project planning	21
3. Preparation	22
3.1. About preparation	22
3.2. Permits	23
3.2.1. Power connection	23
3.2.2. Construction permit	23
3.2.3. Internet access	23
3.3. Upgrade grid	24
3.4. Location	24
3.5. Geometry of infrastructure	25
3.5.1. Required space for the Power Cabinet	25
3.5.2. Placement of multiple cabinets	27
3.5.3. Required space for the Depot Charge Box	27
3.1. Parking space arrangement	28
3.1.1. Cable reach	28
3.1.2. Different alignment possibilities	28
3.2. Electrical engineering	30
3.2.1. Electrical installation	30
3.3. Civil installation	31
3.4. Lightning protection	33
4. Construction	34
4.1. About construction	34
4.2. Construct foundation of the Power Cabinet	35
4.2.1. Options	35

4.2.2.	Workflow with pre-fabricated concrete foundation	36
4.2.3.	Workflow with metal frame foundation	38
4.2.4.	Workflow mounting Power Cabinet direct on a floor (footprint)	39
4.3.	Mounting preparation of the Depot Charge Box	40
4.3.1.	Options	40
4.3.2.	Workflow with concrete foundation	40
4.3.3.	Workflow for wall mounting	42
4.4.	Cabling	43
4.4.1.	Charge system configurations	43
4.4.2.	AC power cable	45
4.4.3.	Cables between the Power Cabinet and the Depot Charge Box	46
4.4.4.	Cables between the Depot Charge Boxes	46
4.4.5.	Grounding of Depot Charge Boxes	46
4.4.6.	Optional external interface cables	47
4.4.7.	Cable specification list	48
4.5.	Internet connection	49
5.	Placement and Connection	50
5.1.	About placement and connection	50
5.2.	Route the cables	51
5.3.	Unpack Power Cabinet	52
5.3.1.	Before unpacking	52
5.3.2.	Remove packaging	53
5.4.	Move Power Cabinet to position	54
5.4.1.	Move cabinet with a hoist	55
5.4.2.	Move cabinet with a forklift truck	56
5.5.	Install Power Cabinet onto the foundation	57
5.5.1.	Connect Power Cabinet to foundation	57
5.5.2.	Open the door of the Power Cabinet	59
5.5.3.	Move the sliding plate of the guidance plates of the cabinet	60
5.5.4.	Route cables through guidance plates	60
5.5.5.	Move sliding plates of the guidance plates of the cabinet	61
5.5.6.	Install border covers of the Power Cabinet	62
5.5.7.	Install border covers of metal frame foundation	62
5.5.8.	Install front cover plate on foundation	63
5.6.	Connect AC power cable and GND wires Power Cabinet	64
5.6.1.	Remove the protection covers	64
5.6.2.	Connect the GND wire of the AC power cable	65
5.6.3.	Connect the AC power cable	66
5.6.4.	Install the protection covers	67
5.6.5.	Install lightning protection (optional)	68
5.6.6.	Connect the GND wire(s) to the Depot Charge Box(s)	69
5.7.	Connect the DC power cables Power Cabinets	69
5.7.1.	Remove the protection cover	70
5.7.2.	Connect the DC power cables	70
5.7.3.	Install the protection cover	71
5.8.	Interlock cable Power Cabinet	71
5.8.1.	Route the cable to the terminal blocks	72
5.8.2.	Connect the Interlock cable	72
5.9.	Connect the communication cable Power Cabinet	73
5.9.1.	Route the cable to the terminal blocks	73
5.9.2.	Connect the communication fiber cables	74
5.10.	Close the door of the Power Cabinet	75
5.11.	Unpack the Depot Charge Box	76
5.11.1.	Before unpacking	76

5.11.2.	Remove packaging	76
5.12.	Install Depot Charge Box onto Pedestal	77
5.12.1.	Connect Pedestal to foundation	77
5.12.2.	Mounting Depot Charge Box onto Pedestal	79
5.13.	Install Depot Charge Box onto wall	80
5.13.1.	Using the wall-mounting brackets	80
5.13.2.	Direct wall mounting	81
5.14.	Connect cables Depot Charge Box	82
5.14.1.	Gland layout of the Depot Charge Box	82
5.14.2.	Open the door of the Depot Charge Box	83
5.14.3.	Remove the protection cover	83
5.14.4.	Connect the GND wire of the Power Cabinet	84
5.14.5.	Install lighting protection (optional)	85
5.14.6.	Connect the GND or lighting protection wire onto Pedestal (when used)	86
5.14.7.	Connect the DC power in- and output cables	87
5.14.8.	Connect the AC auxiliary power cable(s)	88
5.14.9.	Connect the Interlock cable(s)	89
5.14.10.	Connect the communication glass fiber cable(s)	90
5.14.11.	Connect the Ethernet cable between the Depot Charge Boxes	91
5.14.12.	Connect external EMO, Beacon and Stop button cables (optional)	92
5.14.13.	Install the protection cover	93
5.14.14.	Close the door of the Depot Charge Box	94
5.14.15.	Install front cover plate on Pedestal (when used)	94
6.	Commissioning	95
6.1.	Commissioning preparation	95
6.2.	Customer Acceptance Form (CAF)	96
7.	Service and Maintenance	97
7.1.	About Service and Maintenance	97
7.2.	Cleaning of the cabinet	97
8.	Technical Specification	98
8.1.	Electrical specification complete 100 kW system	98
8.1.	Electrical specification complete 150 kW system	99
8.2.	Mechanical data	99
8.3.	Environment	100
8.4.	Certifications	100
9.	Appendix	101
A	Dimensions Power Cabinet	102
B	Dimensions Depot Charge Box	104
C	Dimensions Concrete Foundation	105
D	Dimensions Metal Foundation	107
E	Power Cabinet – Outline with Foundation	108
F	Signal connection diagram	109
G	Ground overview of the system	110

Glossary

AC

Alternating Current.

CAF

Customer Acceptance Form.

CCS (Combo)

Combined Charging System (also called Combo) is the charging protocol for North America and European OEMs.

Contractor

Entity hired by the owner / site operator to do engineering, civil and electrical installation work.

DC

Direct Current.

GFCI

Ground Fault Circuit Interrupter

Grid provider

Company responsible for the transportation and distribution of electricity.

HMI

Human Machine Interface; the screen on the charger.

HVC

Heavy Vehicle Charger.

Power Cabinet

Intermediate unit that provides 150 kW of DC power to the Charge control set. Gets its power from a power distribution board.

Interlock

The Interlock is an isolated current loop and is a feature that makes the state of two

mechanisms or functions mutually dependent.

LAN

A computer network that interconnects computers systems within a limited area.

NOC

ABB Network Operating Centre; remotely checks the correct functioning of the charger.

Owner

The legal owner of the charger.

PPE

Personal Protective Equipment. Equipment such as safety shoes, helmet, glasses, gloves.

RFID

Radio-Frequency IDentification. RFID is a communication technology by means of radio waves to transfer data over a very short distance between a reader and an electronic tag or card.

Site operator

The entity is responsible for the day to day control of the charger. The site operator can be the owner, but not necessarily.

User

The owner of an electric vehicle, who uses the Charge Station to charge that vehicle.

WiFi

A technology that allows electronic devices to connect to a wireless LAN (WLAN) network.

1. Introduction

1.1. Preface

This guide describes the planning and physical installation of the HVC-PD E-Bus Charger at its location for the North American (NA) region.

The HVC-C 100/150 E-Bus Charger is a DC fast charger system for hybrid or electrical buses that can be used for overnight charging which is based on the CCS Charging standard. It is not permitted to use the HVC-C 100/150 E-Bus Charger to charge any other equipment, or to use the HVC-C 100/150 E-Bus Charger for any other purposes.

The HVC-C 100/150 E-Bus Charger uses high-amperage electric currents. Therefore the installation must be planned carefully, and must be done by certified personnel only (according to local standards¹). This equipment is intended to be installed in accordance with the National Electrical Code, NFPA 70.

Before installing the HVC-C 100/150 E-Bus Charger, read this Installation Guide carefully and attentively. Follow the instructions in this Installation Guide. ABB is not responsible for any damage that has been caused by not or incorrectly following and executing the instruction described in this manual.



1.2. Intended document users

This document is intended to be used by:





- Customers who purchased a HVC-C 100/150 E-Bus Charger, or are in the process of ordering and want to know in more detail how it has to be installed.
- Contractors who are responsible for site preparation and/or installation of the HVC-C 100/150 E-Bus Charger.

1.3. Signs

The following signs are used on the equipment and in this manual:

	<p style="text-align: center; background-color: red; color: black; margin: 0;">DANGER</p> <p>Hazardous voltage Identifies a hazard that could result in severe injury or death through electrocution.</p>
	<p style="text-align: center; background-color: yellow; color: black; margin: 0;">WARNING</p> <p>Various Identifies a hazard that could result in severe injury or death.</p>
	<p style="text-align: center; background-color: yellow; color: black; margin: 0;">WARNING</p> <p>Rotating parts Identifies a hazard that could result in injury due to the presence of rotating or moving parts.</p>

¹ Local regulations shall take precedence if they list different installation requirements than prescribed in this Installation Manual.

	<p style="text-align: center;">WARNING</p> <p>Pinch Hazard Identifies a hazard that could result in injuries in which some body parts are pinched or crushed.</p>
	<p style="text-align: center;">WARNING</p> <p>Fall Hazard Identifies a hazard that could result in injury due unsafe work at height.</p>
	<p style="text-align: center;">CAUTION</p> <p>Various Identifies a hazard that could result in damage to the machine, other equipment, and/or environmental pollution.</p>
	<p style="text-align: center;">CAUTION</p> <p>Environmental damage Identifies a special indications as well as biddings and prohibitions to avoid damages in the environment. This sign refer to present national regulation according the environment.</p>
	<p style="text-align: center;">NOTICE</p> <p>Contains remarks, suggestions or advice.</p>

1.4. Safety regulations



1.4.1. Owner responsibilities

The owner and site operator are required:

- To operate the charge station with the protective devices installed and to make sure all protective devices are correctly installed after carrying out installation or maintenance.
- To write an emergency plan that instructs people what to do in case of emergency.
- To prepare the site where the charge station will be installed, according to the requirements described in this guide.
- To make sure that there is enough space around the charger to carry out maintenance work.
- To appoint a person responsible for the safe operation of the charge station and for the coordination of all work.
- All works have to be carried out from qualified personnel. All qualified personnel has to estimate their transmitted works, identify and avoid. They must have experience and enough knowledge over: safety regulations and labor medical regulations, accident prevention regulations, guideline and approved safety regulations, and special instruction concerning occurrence of danger (especially remaining risk) possible dangers.

- You are not allowed to modify the charge system without the permission of ABB. The owner is cautioned that changes or modifications not expressly approved by ABB could void the owner's authority to operate the equipment and ABB's warranty policy.
- Neither ABB nor its affiliates shall be liable to the purchaser of this product or third parties for damages, losses, costs or expenses incurred by purchaser or third parties as a result of: an accident, misuse or abuse of this product or unauthorized modifications, repairs or alterations to this product, or failure to strictly comply ABB operating and maintenance instructions.

1.4.2. Tilting and handling

	<p style="text-align: center;">CAUTION</p> <p>Heavy equipment Handling instructions:</p> <ol style="list-style-type: none"> 1. Use crane or forklift truck when lifting or moving the Power Cabinet. 2. Do not drop parts of the HVC-C 100/150 E-Bus Charger. 3. Do not exceed a tilting of 30° for the Power Cabinet. 4. Read and follow the ABB <i>Guidance on the requirements for safe operation of mobile cranes</i> (ML-03, 9Akk104941D0113).
	<p style="text-align: center;">WARNING</p> <p>Personal safety (PPE) Always wear a safety helmet, safety gloves and safety shoes when you do the lifting and tilting work.</p>
	<p style="text-align: center;">WARNING</p> <p>Make sure that personnel cannot be crushed or become trapped during lifting and tilting work.</p>

Lifting activities

It is a legal requirement that all activities involving lifting equipment are planned and that they are conducted under effective supervision and managed based on the risk, complexity of the activity and the work environment (EU directive 2009/104/EEG, appendix II, chapter 3.2.5).

It is of great importance, regardless of location, that any lifting activity is performed safely, because the activity:

- Carry out within the framework of an effective management system;
- Properly planned;
- Risk has been assessed;
- Supervision is being held; and
- Performed by skilled personnel and with the appropriate means.





All lifting activities must be performed under the ABB *Guidance on the requirements for safe operation of mobile cranes* (ML-03, 9Akk104941D0113).



When applying this Standard, local laws and regulations must be taken into account at all times. In the event of conflicts, local laws and regulations prevail over this Standard.

1.4.3. Electric hazards

	DANGER
	<p>Hazardous voltage The HVC-C 100/150 E-Bus Charger conductors under hazardous electrical voltages. The grid terminals on the internal DIN rail may carry hazardous voltages, even if all circuit breakers are switched off.</p>

1.4.4. Installation safety

	WARNING
	<p>Personal safety (PPE) Always wear a safety helmet, safety gloves and safety shoes when you do the lifting and tilting work.</p>
	WARNING
	<p>Visually examine the package for damage. See section <i>Before unpacking</i> on Page 52 and section <i>Before unpacking</i> on Page 76. If there is damage, do not install the system.</p>
	DANGER
	<p>Hazardous voltage</p> <p>Instructions:</p> <ol style="list-style-type: none"> 1. Always switch off the external group switch and the main switch in the cabinet, before performing any installation, disassembly, repair or replacement of components. 2. Do a voltage check and make sure that the electrical power is disconnected from the system. 3. Only ABB certified technicians are permitted to commission the HVC-C 100/150 E-Bus Charger. 4. When the system is in an open or dangerous condition, do not allow unqualified persons to go near it. Instruct and warn people about the potential harmful high voltages. 5. The installation and maintenance personnel must supply their own lighting equipment, since the HVC-C 100/150 E-Bus Charger has no lights inside the cabinet. 6. Always connect the Protective Earth (GND or PE) first, before connecting the neutral (N) and Phase (P) wiring. 7. Correctly lock the door after installation or service operations.
	WARNING
	<p>Make sure that there is a minimum free space of 39.37 Inch in front of the door of the Power Cabinet. The minimum space is necessary to allow service personnel to quickly move away from the Power Cabinet if there is an emergency when the door is open.</p>

	WARNING
	<p>Make sure that there is a minimum free space of 39.37 Inch in front of the door of the Depot Charge Box. The minimum space is necessary to allow service personnel to quickly move away from the Depot Charge Box if there is an emergency when the door is open.</p>
	CAUTION
	<p>Warranty Installation and commissioning work must be carried out by certified personnel. The warranty will be void if any work carried out by non-certified personnel.</p>

1.5. Environment and disposal of waste

	CAUTION
	<p>Always observe the local rules and regulations with respect to processing (non-reusable) parts of the HVC-C 100/150 E-Bus Charger.</p>

1.6. Contact information

ABB in your country

Please contact ABB in your country for delivery and service information.

ABB EV Infrastructure global

ABB EV Infrastructure

Address Delftweg 65
 2289 BA Rijswijk
 The Netherlands

Telephone +31 70 307 62 00

Mail info.evi@nl.abb.com

Write down here your local ABB contact details:

2. Description of the product

2.1. Overview of the system

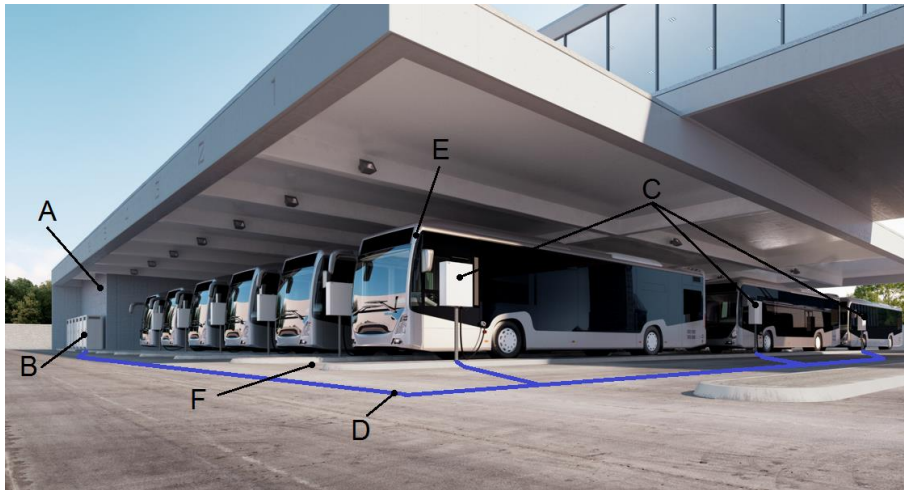

Example of a complete installation

- | | |
|---|---|
| A | Low voltage power distribution cabinet of the owner |
| B | Power Cabinet – 100 kW or 150 kW (HVC 100 or HVC 150) |
| C | Depot Charge Boxes (up to 3 per Power Cabinet with sequential charging) |
| D | Cables between Power Cabinet and Depot Charge Boxes in cable conduits |
| E | Electric hybrid and/or full electric Bus |
| F | Bus stop space for charging |

The HVC-C 100/150 kW E-Bus Charger consists out of multiple components and it may require additional parts depending on the project and location of installation which dictates whether these parts are needed.

ABB offers four standard delivery system configurations:

1. Standard HVC-C 100 E-Bus Charger with one Depot Charge Box.
2. Standard HVC-C 100 E-Bus Charger with two or three Depot Charge Boxes.
3. Standard HVC-C 150 E-Bus Charger with one Depot Charge Box.
4. Standard HVC-C 150 E-Bus Charger with two or three Depot Charge Boxes.

Additional needed components can be ordered separately and are not part of the standard delivery. See section *Accessories* on Page 18.

2.1.1. Standard HVC-C 100 E-Bus Charger with one Depot Charge Box

The following parts are provided for this system configuration:

- 1x HVC 100 Power Cabinet² (ABB6AGC073513)
- 1x Depot Charge Box (ABB6AGC073079) or 1x Depot Charge Box with long cable (ABB6AGC072866)

² For Canada, the HVC 100 CsA (ABB6AGCXXXXXX) is delivered. This Power Cabinet is suitable for 600 V AC 3P grid connection.

2.1.2. Standard HVC-C 100 E-Bus Charger with two or three Depot Charge Boxes

The following parts are provided for this system configuration:

- 1x HVC 100 Power Cabinet³ (ABB6AGC073513)
- 2x or 3x Depot Charge boxes (ABB6AGC073079, with long cable version ABB6AGC072866)
- HVC-C sequential charging package (ABB6AGC069251)

2.1.3. Standard HVC-C 150 E-Bus Charger with one Depot Charge Box

The following parts are provided for this system configuration:

- 1x HVC 150 Power Cabinet⁴ (ABB6AGC070558)
- 1x Depot Charge Box (ABB6AGC073079) or 1x Depot Charge Box with long cable (ABB6AGC072866)

2.1.4. Standard HVC-C 150 E-Bus Charger with two or three Depot Charge Boxes

The following parts are provided for this system configuration:

- 1x HVC 150 Power Cabinet⁴ (ABB6AGC070558)
- 2x or 3x Depot Charge boxes (ABB6AGC073079, with long cable version ABB6AGC072866)
- HVC-C sequential charging package (ABB6AGC069251)

³ For Canada, the HVC 100 CsA (ABB6AGCXXXXX) is delivered. This Power Cabinet is suitable for 600 V AC 3P grid connection.

⁴ For Canada, the HVC 150 CsA (ABB6AGCXXXXX) is delivered. This Power Cabinet is suitable for 600 V AC 3P grid connection.

2.1.5. HVC Power Cabinet

Outside view of the HVC 100⁵/150 Power Cabinet

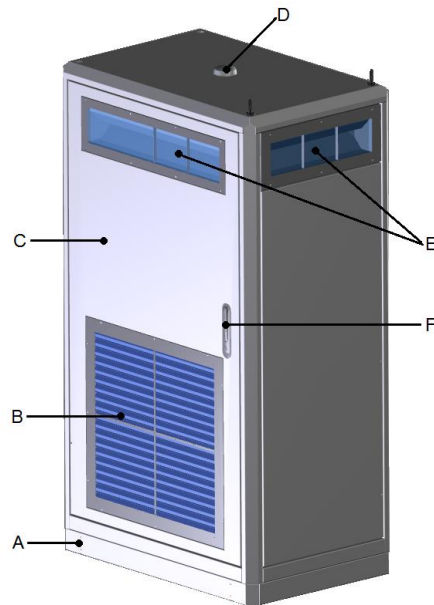

- | | | | |
|---|------------|---|---|
| A | Base cover | D | 3G Antenna |
| B | Air outlet | E | Air inlets (also on the left and back side) |
| C | Door | F | Door handle / lock |

Inside view of the HVC 100/150 Power Cabinet

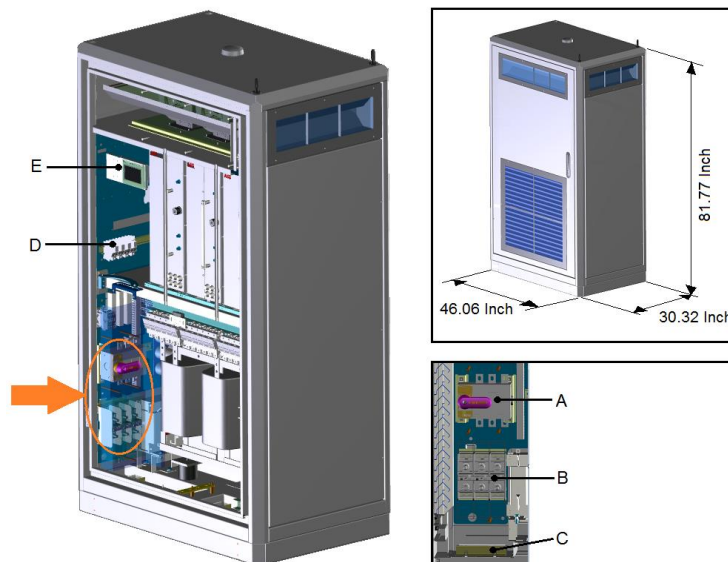

- | | | | |
|---|-------------------------------|---|--|
| A | Main switch | E | Display |
| B | AC Power connection | F | Power Modules (only two are installed in the HVC 100). |
| C | Guidance plate of the cables | | |
| D | Data/communication connection | | |

⁵ Two 50 kW Power Modules installed in the cabinet instead of three.

2.1.6. Depot Charge Box

Outside view of the Depot Charge Box

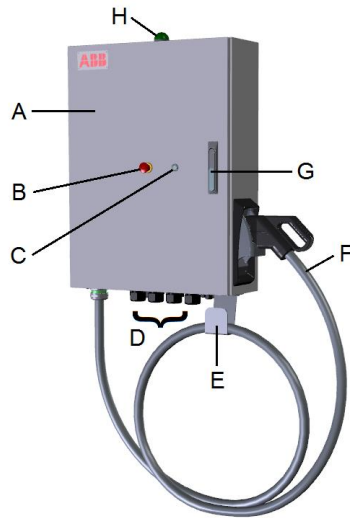

- | | | | |
|---|-----------------------------|---|---------------------------------------|
| A | Door | E | Hanging bracket for charge cable |
| B | Emergency stop button (EMO) | F | CCS DC plug and cable |
| C | Stop button | G | Lock |
| D | Cable in-/output | H | Charge state indicator light (beacon) |

Inside view of the Depot Charge Box

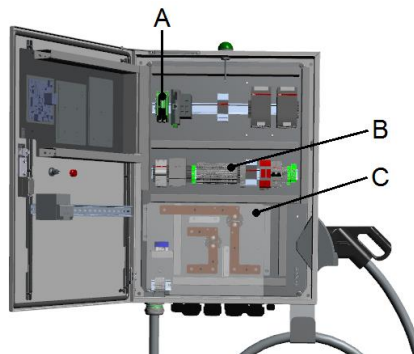

- | | |
|---|------------------------------------|
| A | Communication connection |
| B | Connection block |
| C | Protection cover for DC contactors |

2.2. Accessories

The following parts can be ordered at the time of the initial order or afterwards. Contact ABB Sales department (see *Contact information* on Page 13 for contact details).

2.2.1. Foundation for Power Cabinet

Concrete foundation

The concrete foundation can be used to install the Power Cabinet on soil.

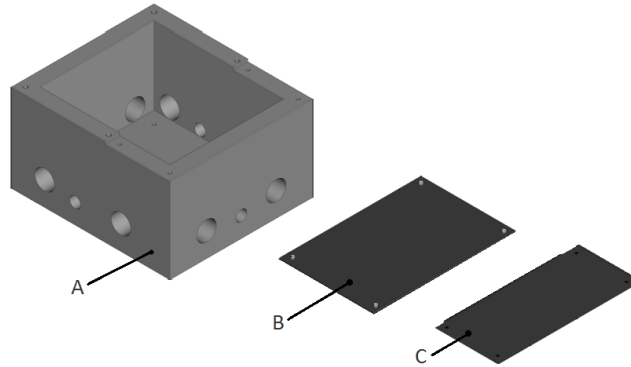

- A Foundation
- B Top cover plate
- C Front cover plate

Amount	Part number	Description
1	ABB6AGC069029	HxC power cabinet foundation & front cover plate
1	ABB6AGC067780	HxC power cabinet foundation top cover plate

Metal frame foundation

The metal frame foundation can be used to install the Power Cabinet on a solid surface.

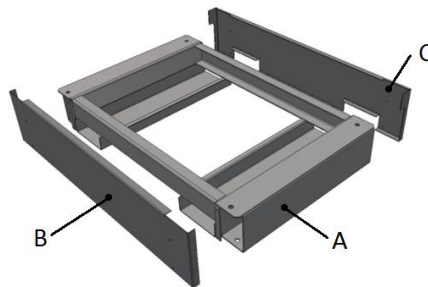

- A Foundation
- B Front border cover
- C Rear border cover

Amount	Part number	Description
1	4EPY420133R1	HxC power cabinet metal foundation

2.2.2. Pedestal for Depot Charge Box

The pedestal can be used to attach the Depot Charge Box in an open space when the Depot Charge Box is not being mount on a wall.

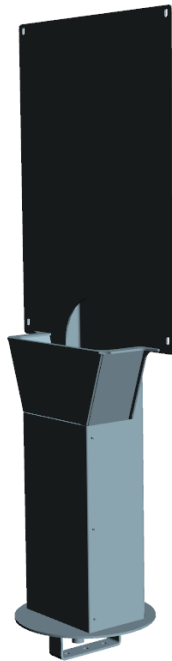

Amount	Part number	Description
1	ABB6AGC069024	HVC-C pedestal charge box

2.2.3. Foundation for pedestal

Unimi-1Base™ pre-cast concrete foundation

The concrete foundation must be used to install the pedestal on soil.

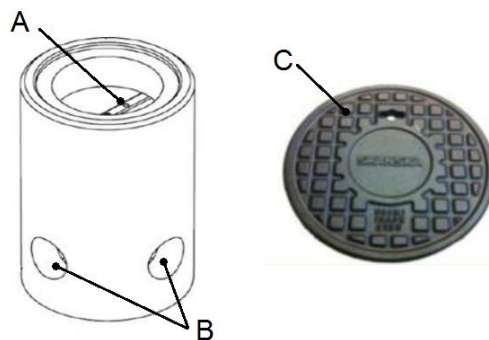

- A Beam
- B Conduit entry
- C Cover plate (only needed when the foundation is temporarily not used)

Amount	Part number	Description
1	ABB6AGC069025	HVC-C concrete foundation depot charge box

2.2.4. Wall-mounting brackets for safe wall fixing

The Depot Charge Box can be easily mounted at the installation site without any need for internal access.



Amount	Part number	Description
1*	AWS41-304	Wall-mounting brackets, SS304 (ELDON)

(*) pack quantity is 4

2.2.5. Communication glass fiber cable

The CAN/Ethernet communication between the Power Cabinet and Depot Charge Box and the CAN communication between the Depot Charge Boxes is done via a glass fiber cable. This glass fiber cable must be prefabricated and can be ordered separately.

If glass fiber cable is not supplied by ABB, then gland dimensions listed in section *Gland layout of the Depot Charge Box* on Page 82 must be followed. Please note that special precautions should be taken, so that pre-fabricated fiber optic cable will pass through the gland (for example order cable with M32 gland assembled on it). Another alternative could be to crimp the fiber optic cable on the site after passing through the gland.

Cable length must be defined by the contractor performing installation during site survey.



- A Protection tube for routing the cable through the conduit
- B Metal finish tulle (clamping area: Ø 0.79 Inch, length 1.97 – 3.15 Inch)
- C Individual optical fibers (length is 59.10 Inch)

Amount	Part number	Description
1	Contact ABB for details	CAN/Ethernet, OM3, PCF or fiberglass (multimode, 850 nm) optic cable with 8 fibers (4 for spare), with B-FCO(ST®) connectors. Example: Belden GOSN308 with prefabricated ST connectors.
1 or 2(*)	Contact ABB for details	CAN, OM3, PCF or fiberglass (multimode, 850 nm) optic cable with 4 fibers (2 for spare), with B-FCO(ST®) connectors. Example: Belden GOSN304 with prefabricated ST connectors.

(*) only for the charge systems with three Depot Charge Boxes

2.3. Project planning

Careful project planning is necessary before a HVC-C 100/150 E-Bus Charger is purchased and put into operation. The different phases of the full project plan are shown in the figure below:

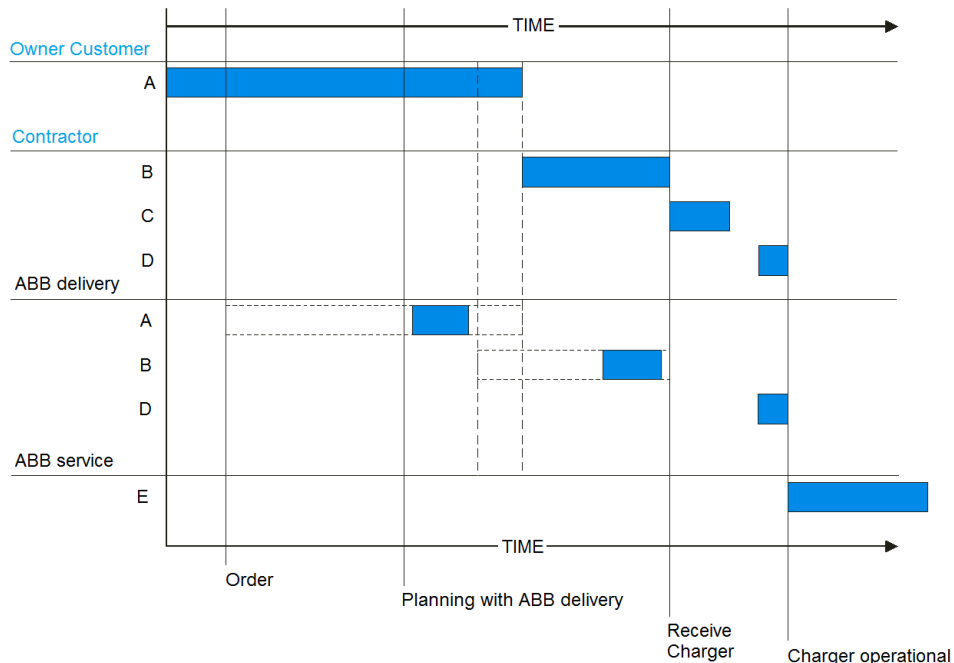

A. Preparation

The owner / site operator has ordered a HVC-C 100/150 E-Bus Charger. In this phase all preparation work must be done before the contractor can do the civil and electrical works. See *About preparation* on Page 22.

B. Construction

The contractor does all civil and electrical works. See *About construction* on Page 34.

C. Placement and Connection

The location is mechanically and electrically ready to receive the HVC-C 100/150 E-Bus Charger. See *About placement and connection* on Page 50.

D. Commissioning

The delivery department will bring the HVC-C 100/150 E-Bus Charger into operation. See *Commissioning preparation* on Page 95.

E. Service and Maintenance

The HVC-C 100/150 E-Bus Charger is in operation. There are various options for service and maintenance. See *About Service and Maintenance* on Page 97.

3. Preparation

3.1. About preparation

The planning steps for the preparation phase are shown in the figure below:

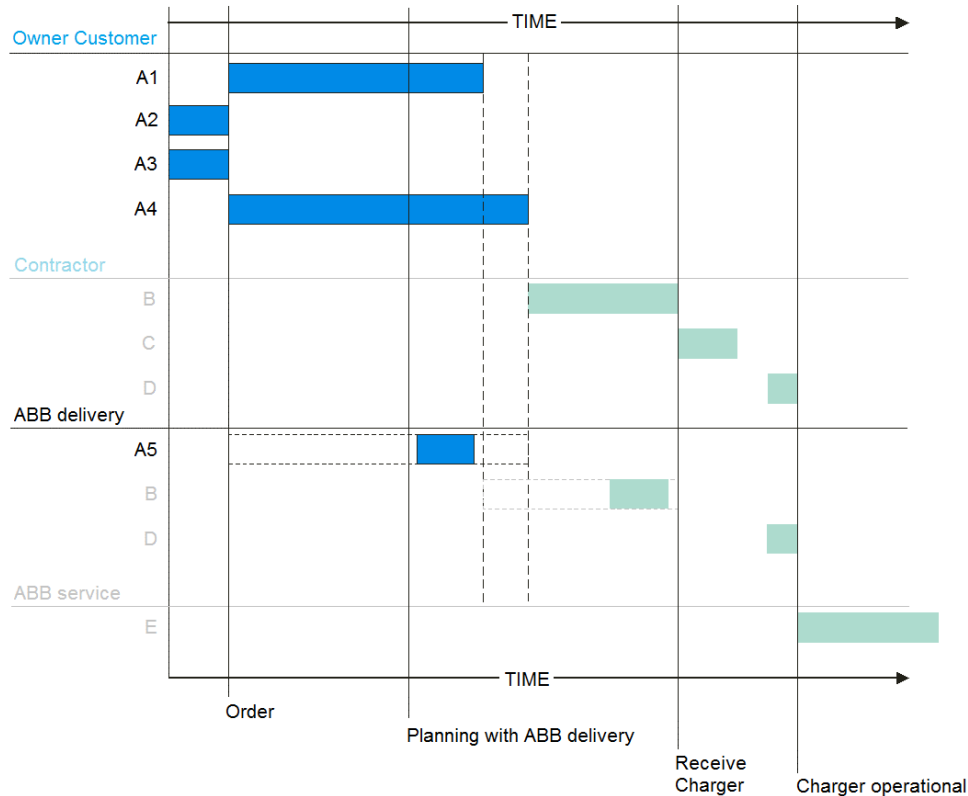

A1 **Ordering**

Order the HVC-C 100/150 E-Bus Charger.

A2 **Engineering**

The owner / site operator selects a contractor to do the civil and electrical installation work. The contractor is responsible for all construction documentation of the site, among other things: drawings, calculations, certifications, licenses and test reports. The location of the HVC-C 100/150 E-Bus Charger must be chosen. See section *Location* on Page 24 and section *Geometry of infrastructure* on Page 25.

A3 **Get permits**

Take care of all permits and local regulations. See section *Permits* on Page 23.

A4 **Upgrade grid**

If required, upgrade the electrical grid connection to 3-phase 480/277 V AC or 600/347 V AC. See section *Upgrade grid* on Page 24.

A5 **Transport foundation(s) on request**

If it is necessary to order the foundation(s), the transport of the foundation(s) must be arranged with the ABB Delivery department. See *Contact information* on Page 13 for contact.

**NOTICE**

It can take a long time to get the necessary permits and to upgrade the electrical grid. Make sure the plan includes the possibility for these delays.

3.2. Permits

The installation of a HVC-C 100/150 E-Bus Charger will require a number of permits, depending on national and local laws. This section lists a number of points of attention.

3.2.1. Power connection

The HVC Power Cabinet requires high current (480/270 V AC 132 A for 100 kW and 198 A for 150 kW or for the Canada version 600/347 V AC 106 A for 100 kW or 163 A for 150 kW) connections. A normal domestic or small business power connection is not sufficient. For each Depot Charge Box a standard one phase AC connection (L-N + GND) is required.

Measure, check and report the position of the cables between the power distribution board and the Power Cabinet and the cables between the Power Cabinet and the ACS Control Module.

Contact your electricity retailer and/or grid owner if a grid upgrade is required. Ask about the work that is needed to upgrade the connection to meet the requirements described in section *Electrical installation* on Page 30.

3.2.2. Construction permit

The installation of the HVC-C 100/150 E-Bus Charger requires the following construction work:

- A solid base.
- Work permit.
- Cable conduits for cables between the power distribution board and the Power Cabinet. Usually these cable conduits are installed below ground.
- Cable conduits for cables between the Power Cabinet and ACS Control Module.
- Parking spaces for the bus.
- Signs on the road or next to the road to position the bus.

Contact your local government to obtain information about the necessary permits.

3.2.3. Internet access

The HVC-C 100/150 E-Bus Charger requires a connection to the internet. This connection is used for serviceability, remote access by ABB Service department.

There are two options for the internet connection:

- Wireless, which requires coverage to a 3G network at the location. This is the preferred connection. A 3G modem with active SIM card is included with the HVC-C 100/150 E-Bus Charger (a customer SIM card is not required).
- Ethernet (RJ45). If there is no 3G signal available, a wired internet connection must be available at the location. For this option, contact ABB Sales department (see *Contact information* on Page 13 for contact details).

3.3. Upgrade grid

The HVC 100 or 150 Power Cabinet can be connected directly to the electrical grid or to an existing customer low voltage power distribution cabinet. In both cases a 220 A, 480/277 V AC or for the Canada version a 163 A, 600/347 V AC, 60 Hz, 3P+GND connection to each Power Cabinet (HVC 150 or HVC 150S) is required. For each Power Cabinet (HVC 150 or HVC 150S) the following requirements apply:

- Fuse (gG type or fast-acting J type) 3 x 300 A AC or 3 phase 285 A Ground Fault Circuit Interrupter (GFCI).
- Main switch.
- GND connected to the main GND rail.
- The components used in the HVC-PD E-Bus Charger are suited for a short circuit capacity of 25 kA.
- A TN-C earthing system. Possibly an extra 0.9 Ω earth electrode is required, consult the grid owner.
- EMC filter is required to meet EMC conducted emission class B: Schaffner type FN 3359HV-400-99. When EMC conducted emission class A is required there is no filter required.
- Specifications of the following parts must be determined by your electrical engineer. They depend on local laws, safety and electrical regulations:
 - Adjustable GFCI in the range of 30 mA up to 300 mA. The Power Cabinet has an integrated 300 mA GFCI (Type A) for the power section.
 - UL 1449 Type 1 Surge Protection Device (SPD).

The Depot Charge Box can be connected directly to the electrical grid or to an existing customer low voltage power distribution cabinet. In both cases a 2.2 A, 120 V AC, 60 Hz, 1P+GND connection is required. For each Depot Charger Box the following requirements apply:

- 1 phase 16 A type A (30 mA) Ground Fault Circuit Interrupter (GFCI).
- Main switch.
- GND connected to the main GND rail.
- A TN-S earthing system. Possibly an extra 0.9 Ω earth electrode or local GND is required, consult the grid owner.
- Specifications of the following parts must be determined by your electrical engineer. They depend on local laws, safety and electrical regulations:
 - UL 1449 Type 1 Surge Protection Device (SPD).
- If circuit breaker is used in distribution cabinet, then specification of Inrush current of Depot Charge Box must be taken into account during sizing of protection. Maximum inrush current: 100 A < 5 ms.

3.4. Location

The location of the HVC-C 100/150 E-Bus Charger must meet the following requirements:

- The charging system should not be installed in the hazardous location identified per the standard ANSI/API RP 500-2012: Recommended Practice for Classification of Locations of Electrical Installations at Petroleum Facilities Classified as Class I, Division 1 and Division 2.
- The height is not more than 6561.68 ft above sea level.
- The HVC-C 100/150 E-Bus Charger must not be immersed in water, or any other fluid.
- The operational temperature of the HVC-C 100/150 E-Bus Charger is between -35 and 45 °C.

- For locations where the Power Cabinet will be exposed to direct sunlight and high ambient temperatures for most of the day, it is recommended to install protection from direct sunlight. Otherwise the temperature inside the cabinet might exceed the maximum temperature.
- Do not install or use the HVC-C 100/150 E-Bus Charger in areas where there is an explosion hazard. You must provide information about the HVC-C 100/150 E-Bus Charger to the fire brigade.
- The protection rating of the housing of the Power Cabinet is IP54 and the Depot Charge Box is IP65 (excluding charge cable) and designed for outdoor use.
- It is recommended to provide good lighting around the charge system to increase safety.
- Design and arrange the location around the HVC-C 100/150 E-Bus Charger on a matter that the Depot Charge Box and the Power Cabinet are hit by a vehicle is as small as possible. For example, there can be installed bollards (see picture below) around the Power Cabinet and crash protection elements can be fitted to the Unimi-1Base™ pre-cast concrete foundation (see section *Workflow with concrete foundation* on Page 40).

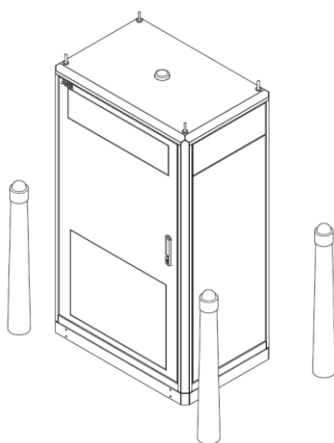

3.5. Geometry of infrastructure

3.5.1. Required space for the Power Cabinet

A single HVC 150 Power Cabinet requires a minimum space of 46.06 x 81.50 Inch (W x D) or 53.94 x 77.56 Inch (W x D). This space is calculated as follows:

- A cabinet footprint of 46.06 x 30.32 Inch.
- The following free space around the cabinet:
 - 3.94 Inch at the rear side or 0 Inch at the rear side when both left and right side have a minimum free space of 3.94 Inch.
 - 3.94 Inch or 0 Inch at the left side, if another Power Cabinet is placed next to it.
 - 3.94 Inch or 0 Inch at the right side, if another Power Cabinet is placed next to it.
 - 47.24 Inch at the front side in order to open the front door. If the cabinet is placed inside a room, consider extra free space in front of the open door (escape way for service people).

	CAUTION
	<p>The cabinet needs at least the opening area of the front and rear side with a minimum free distance of 3.94 Inch. This means that cabinets can stand in a row with one or both side entries blocked (distance on left/right side is 0 Inch).</p> <p>It is also possible that the cabinet can stand back to back (distance on the rear side is 0 Inch). In this case both side entries must have a minimum free distance of 3.94 Inch. If this is not the case, then the air supply is not sufficient.</p>

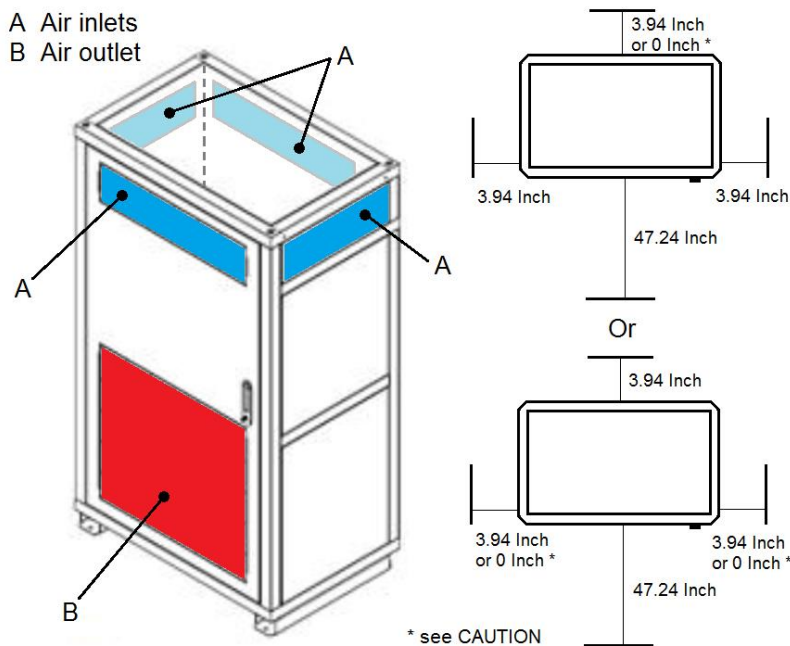

The HVC 100/150 has air inlets (A) on all sides and air outlet (B) on the front to control the temperature inside the cabinet. Do not install any objects near these air inlets and outlets (see also Caution above). If necessary, take precautions to prevent snow, sand or dust from blocking the inlets and outlets.

Specifications for inside installation of the Power Cabinet

- Airflow required for one cabinet = 51206.27 ft³/h.
- Maximum allowed pressure drop = 300 pA. If the pressure drop of the room is higher than 300 pA an extra fan should be placed. Contact ABB Sales department (see *Contact information* on Page 13 for contact details).

3.5.2. Placement of multiple cabinets

There two possible configurations for the placement of multiple HVC 100/150 systems, see picture below.

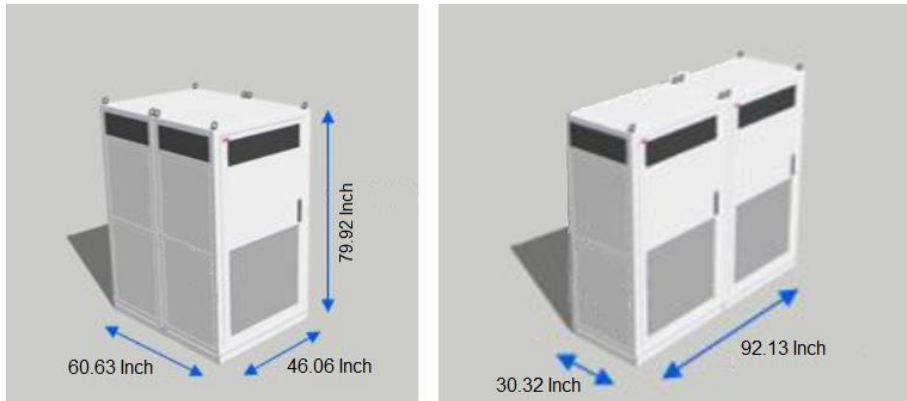

3.5.3. Required space for the Depot Charge Box

The Depot Charge Box requires a minimum space of 47.24 x 43.70 Inch (W x D). This space is calculated as follows:

- A Depot Charge Box footprint of 23.62 x 8.27 Inch (W x D).
- The following free space:
 - 0 Inch at the rear side when the Depot Charge Box is directly mounted on a wall or minimum 3.94 Inch at the rear side when the Depot Charge Box is in front of a wall and mounted on the pedestal.
 - 3.94 Inch at the left side.
 - 19.69 Inch at the right side to take out the cable plug.
 - 35.43 Inch at the front side to open the door.

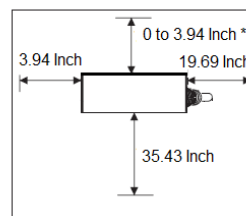

* when placed in front of a wall and using the pedestal, recommended to keep 3.94 Inch of space.

3.1. Parking space arrangement

A site for EV charging can be designed in many different setups. This section is intended to give some useful information about the placement of a charger with respect to parking spaces and the different vehicle inlets for the charging cable.

3.1.1. Cable reach

The DC charge cable of the Depot Charge Box is about 11.48 ft long (optional there is a 22.97 ft cable possible). The picture below shows an indication of the reach of the outlet cable with respect to the Depot Charge Box. Here in the center of the picture.

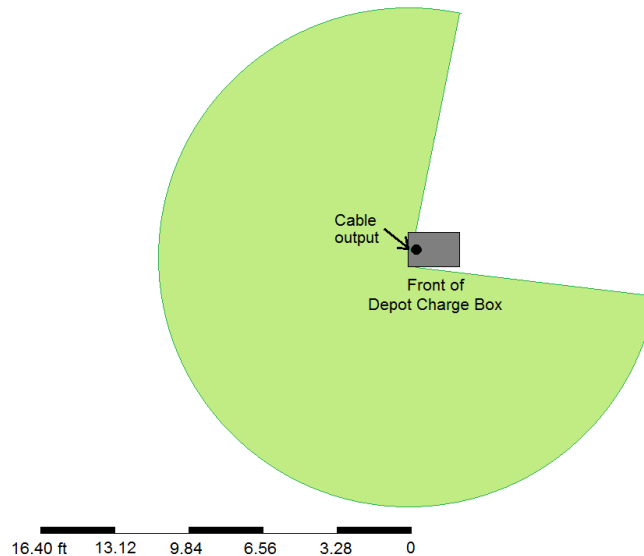

3.1.2. Different alignment possibilities

The charge inlets on a bus can be located at different positions. The most common busses have their inlets located either on the front or the back of the bus, or on the left or right front or back side.

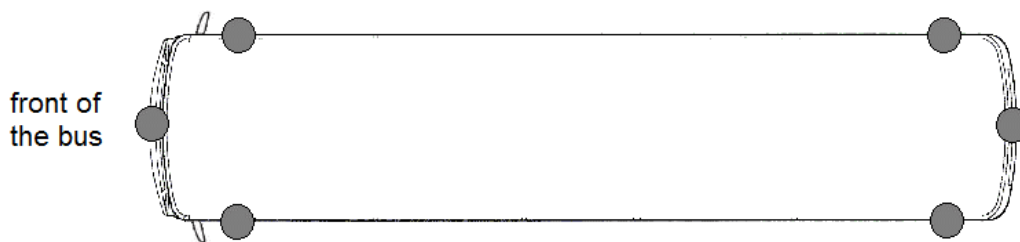

This makes some positions of the charger with respect to the parking space more favorable than others. Please keep this in mind when designing a site. Some possible situations are shown in the picture that follows.

Forward parking

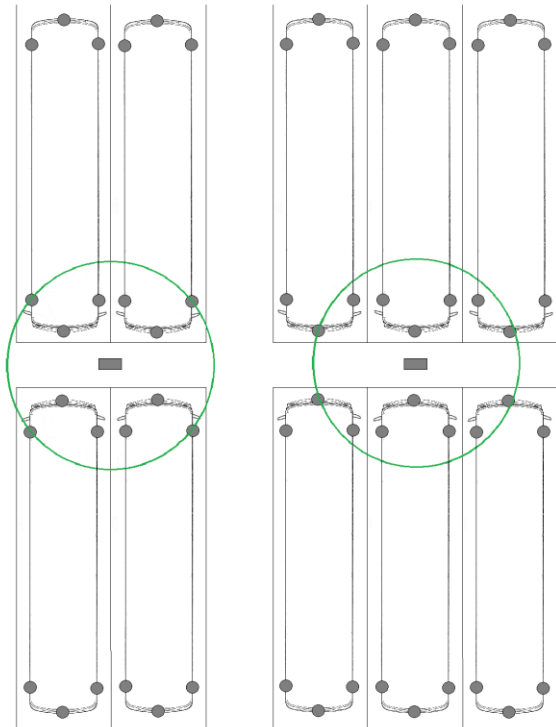

Backward parking

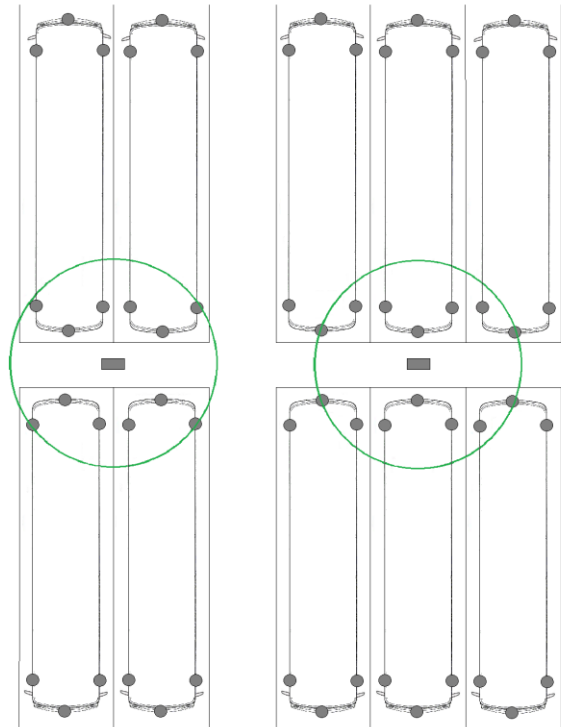

Drive through

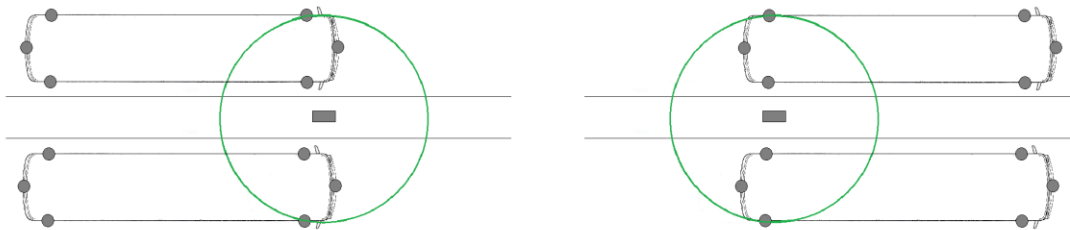

3.2. Electrical engineering

3.2.1. Electrical installation

The electrical installation must be completed according to the local safety and electrical regulations and laws. See section *Upgrade grid* on Page 24 for the requirements of the electrical connection. A one line diagram for the electrical connection for the Power Cabinet is shown in the figure that follows. The diameter of the electrical conductor (maximum cross section is 500 MCM) in the AC power cable depends on the length and method of installation. This must be determined by your contractor.

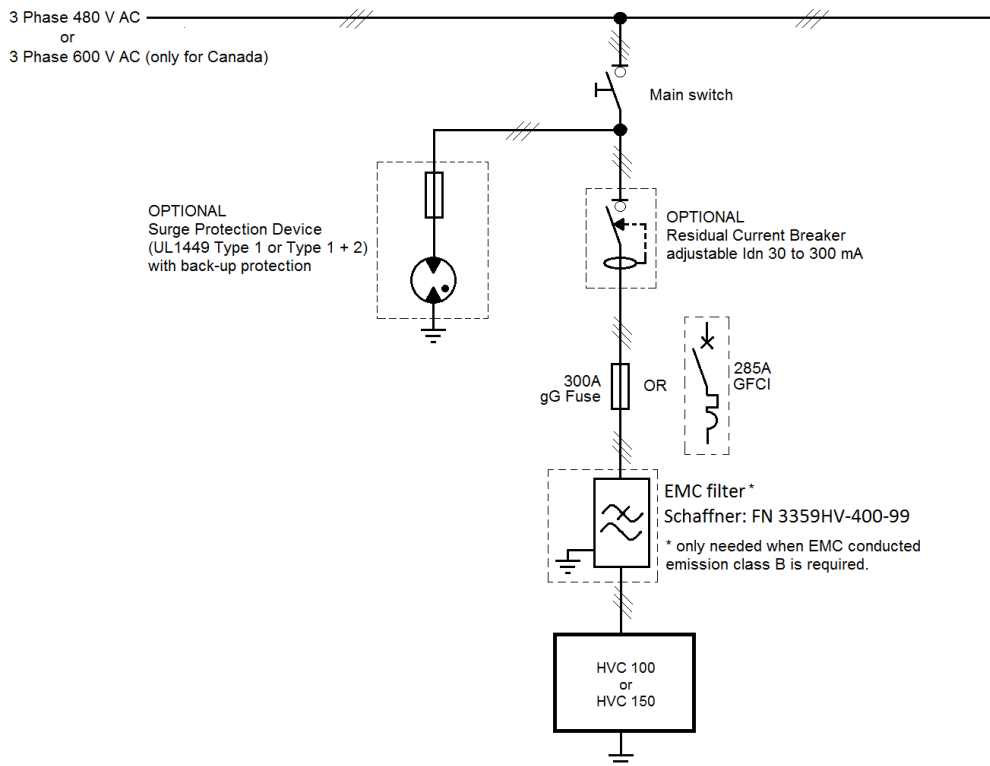

There are two options to connect the AC auxiliary power supply for the Depot Charge Boxes to the electrical grid.

First option is an individual electrical connection for the Depot Charge Box(es). The one line diagram is shown below.

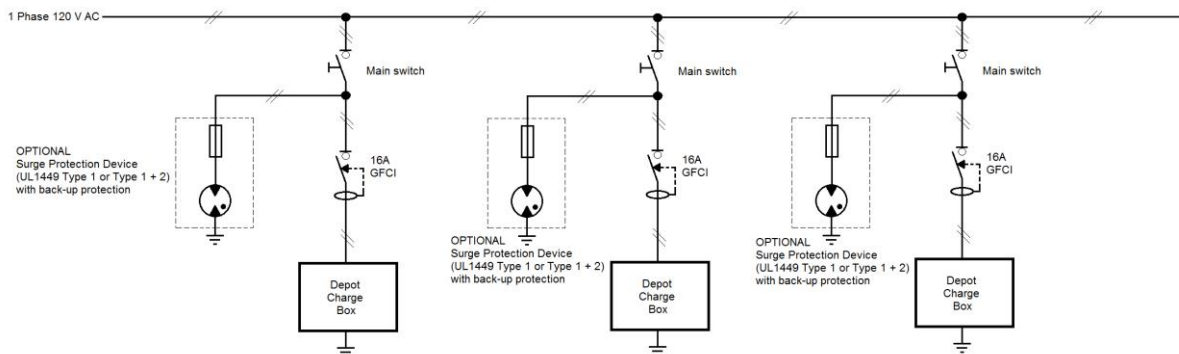

The second option is to daisy-chain the electrical connection through each Depot Charge Boxes, see the one line diagram shown below.

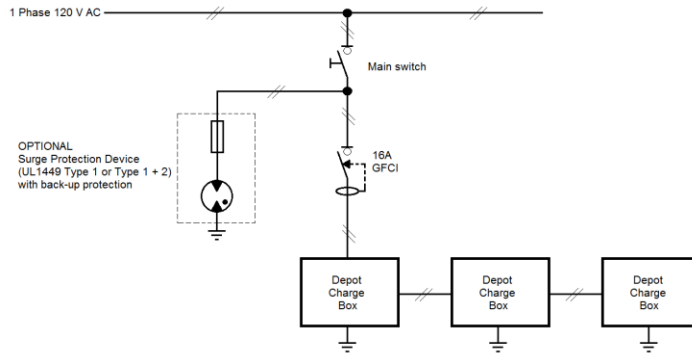

Grounding of Depot Charge Box can be connected from Power Cabinet or from locally available ground connection, such as buried ground electrode. This should be taken into consideration while preparing civil works.

3.3. Civil installation

NOTICE	
	<p>The instruction described in this section assumes that the cables between the Power Cabinet and the Depot Charge Box, and between the Depot Charge Boxes are placed in to the ground. Depending on the location, for example the HVC-C 100/150 E-Bus Charger is installed inside, the cables can installed above the ground. In this case there is needed cable trays to protect the cables. Check with your local contractor what the installation options are, because this is not described in this Installation Guide.</p>

DC power cables, GND wire and data cables must be routed between the Power Cabinet and the Depot Charge Box. Therefore two flexible cable conduits with an outer diameter of maximum 6.30 Inch must be installed between the foundation of the Power Cabinet and the foundation of the Depot Charge Box(es).

The DC power cables must be installed in separate cable conduit with respect to the GND wire, AC auxiliary power and data cables. The maximum length of the cables between the Power Cabinet and the Depot Charge Box is 492.13 ft. Both conduits must be at least 23.62 Inch deep in the ground and must be in one-piece.

In the case of HVC-C 100/150 E-Bus Charger with two or three Depot Charge Boxes; DC power cables, AC auxiliary power, GND wire and data cables must be routed between the Depot Charge Boxes. The DC power cables must be installed in separate cable conduit with respect to the AC auxiliary power, GND wire and data cables. The maximum length of the cables between the Depot Charge Boxes is 98.43 ft. Both conduits must be at least 23.62 Inch deep in the ground and must be in one-piece.

The AC power cable from the distribution boards can also be installed in a cable conduit (is not mandatory).

NOTICE	
	<p>It is recommended to place an extra flexible cable conduit with an outer diameter of 1.58 Inch in the cable conduit intended for the AC utility power cable, GND wire and data cables. This extra cable conduit is meant for the glass fiber cable.</p>

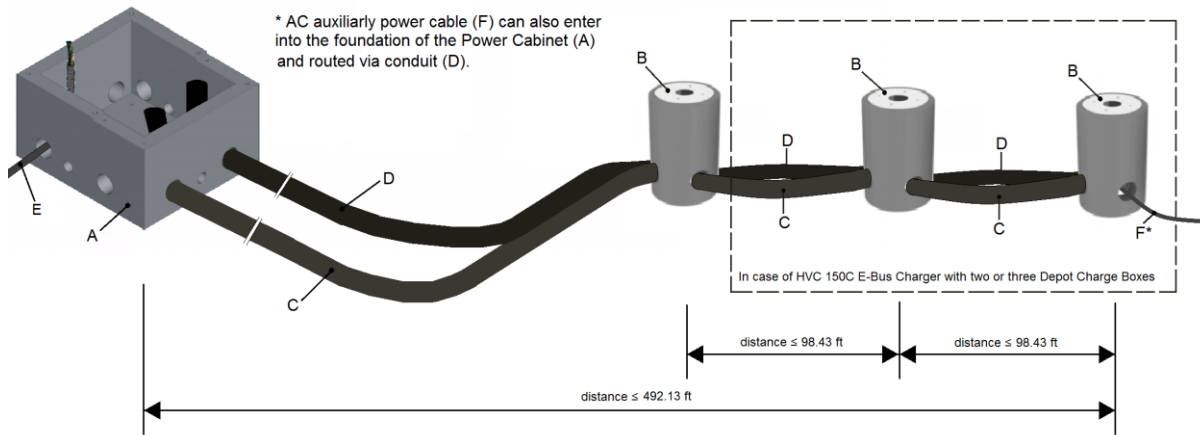

Example of civil installation when Depot Charge Box(es) are mounted on the pedestal

- A Foundation of Power Cabinet
- B Foundation of Depot Charge Box(es)
- C Flexible conduit for DC power cables
- D Flexible conduit for AC auxiliary power, GND wire and data cables
- E AC power cable for Power Cabinet
- F AC auxiliary power cable for Depot Charge Box

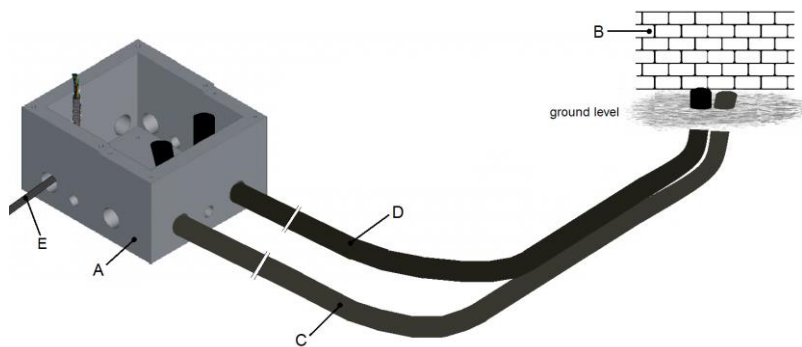

Example of civil installation when Depot Charge Box is mounted on a wall

- A Foundation of Power Cabinet
- B Wall on which the Depot Charge Box will be mounted
- C Flexible conduit for DC power cables
- D Flexible conduit for AC auxiliary power, GND wire and data cables
- E AC power cable for Power Cabinet

NOTICE	
	<p>Document the location of all the cables in the ground between the Power Cabinet and the Depot Charge Box(es). The routing of the cables can be found easily in the future, for example, prevent damage by excavation work.</p>

3.4. Lightning protection

One electrode (ground rod) of maximum 10 Ω must be placed in to the earth near the foundation of the Power Cabinet. In some cases also additional grounding is required at the Depot Charge Box side. This is dependent on the local regulations and should be determined by the contractor.

If the grid is TT based, consult the grid owner. It is possible that an extra 0,9 Ω electrode will be required. This requirement must be determined by the contractor.

Consult a local specialist for the options of lightning protection. The charge system has to be within the protection angle of the lightning distraction. This requirement must be determined by the owner and a local specialist (according to NFPA 780).

The implementation of the lightning protection depends on the local laws, safety and electrical regulations. This requirement must be determined by the contractor and owner of the site / HVC-C 100/150 E-Bus Charger.

4. Construction

4.1. About construction

The construction phase includes all work required to prepare the location and make it ready for the placement and connection of the HVC-C 100/150 E-Bus Charger. The construction phase can start when:

- All engineering work is done.
- All permits are granted.
- The grid connection is available.

The planning steps for the construction phase are shown in the figure below:

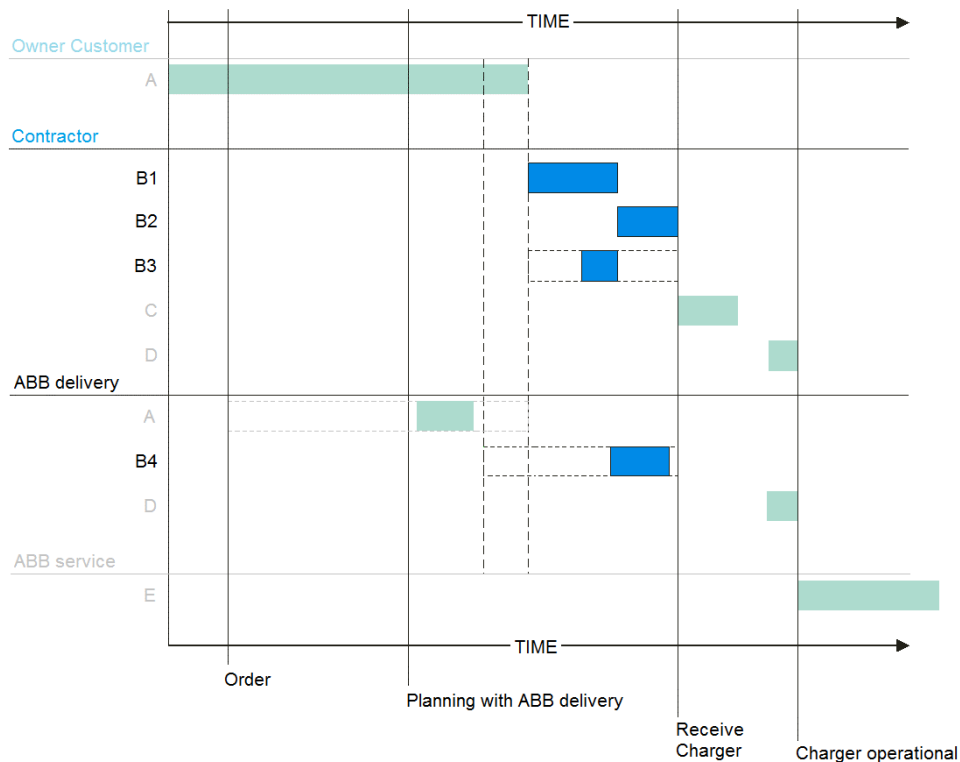

B1 Civil engineering works

Construction of the foundation. See section *Construct foundation of the Power Cabinet* on Page 35 and section *Mounting preparation of the* on Page 39. Installation of the cables. See section *Cabling* on Page 43. Construction of the bus stop surrounding. See section *Geometry of infrastructure* on Page 25.

B2 Electrical engineering works

See section *Electrical engineering* on Page 30 and section *Upgrade grid* on Page 24.

B3 Internet access (optional)

This step can be ignored if the location has sufficient 3G coverage. Otherwise an Ethernet (RJ45) connection has to be installed. See section *Internet connection* on Page 49.

B4 Transport



Arrangement for the delivery of the HVC-C 100/150 E-Bus Charger with the ABB Delivery department. See *Contact information* on Page 13 for contact details. The delivery time is at least four months.

4.2. Construct foundation of the Power Cabinet**4.2.1. Options**

Use the correct foundation for the type of surface that the Power Cabinet will be installed on:



- **Soil**
Use a concrete foundation to get a firm fixation on soil.
A concrete foundation can be ordered separately. See section *Accessories* on Page 18. For detail drawings see Appendix D *Dimensions concrete foundation Power Cabinet*.
- **Solid floor**
 1. Use a metal frame foundation to guide the cables from the cabinet to the cable duct. This foundation can be ordered separately. See section *Accessories* on Page 18. For detail drawings see Appendix E *Dimensions metal frame foundation Power Cabinet*.
 2. The Power Cabinet is installed directly on a solid floor, through which the floor is accessible from below (related to the feed through of the cables). For detail drawings see Appendix A *Dimensions Power Cabinet*.

The cables must be embedded in the ground within cable conduits. See section *Cabling* on Page 43 and section *Civil installation* on Page 31.

	NOTICE
	It is advised to install traction wires into the conduits to install the electrical cabling afterwards.
	NOTICE
	Be aware of the bending radius of the AC power input cables when using the metal frame foundation. This metal frame foundation has a height of 7.09 Inch.

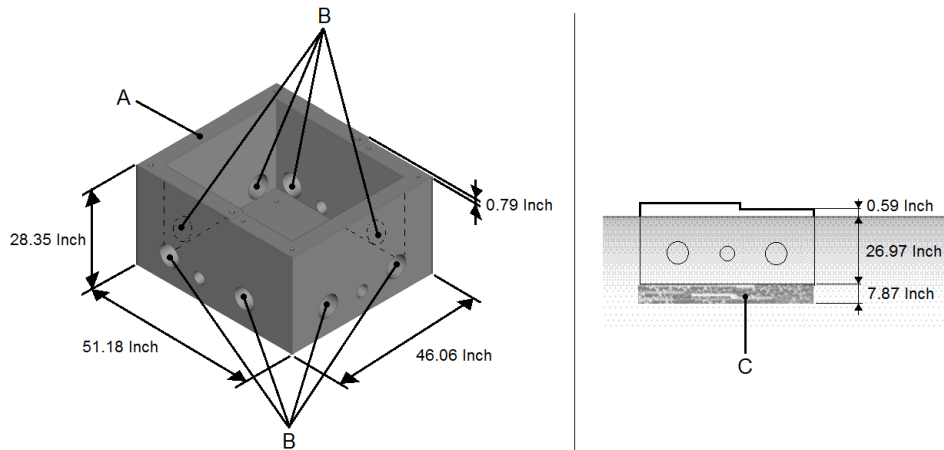
4.2.2. Workflow with pre-fabricated concrete foundation



	WARNING
	<p>Make sure that personnel cannot be crushed or become trapped while moving the foundation. Be aware that the weight of the concrete foundation is about 2866 lb.</p>
	CAUTION
	<p>Before you lower the foundation, remove sharp edges of the cable holes (B) in the foundation to protect the cables.</p>

1. Make a hole in the ground with at least a minimum depth of 34.84 Inch, shown in the figure above.
2. Fill the hole with (minimum) 7.87 Inch lean concrete (C), see figure above.
3. Make sure that the conduits are routed to one of the indicated positions (B). The conduits must come out of the foundation with a length of about 9.84 Inch.
4. Make sure that the AC power cable is routed to one of the indicated positions (B).
5. Lower the foundation (A) into the hole.
6. Make sure that the front top surface of the foundation is at least 0.59 Inch above ground level (see figure above).
7. Make sure that the top surface of the foundation is leveled.
8. Route the conduits through one of the eight holes (B).

	NOTICE
	<p>Make sure that the end of the cable conduits are 11.81 to 19.69 Inch above the top of the foundation.</p>

9. The conduits must be installed with a curve inside the foundation in order to prevent water from entering the conduits, and seal the space between the conduits and all open holes.
10. Route the AC power cable through one of the eight holes (B). Make sure that a cable length of 39.37 Inch is available above the surface of the foundation for internal routing in the cabinet.

	NOTICE
	<p>This extra cable length is required to connect the AC power cable with the connectors in the Power Cabinet without problems.</p>

11. Place both cover plates on the appropriate place on the foundation.

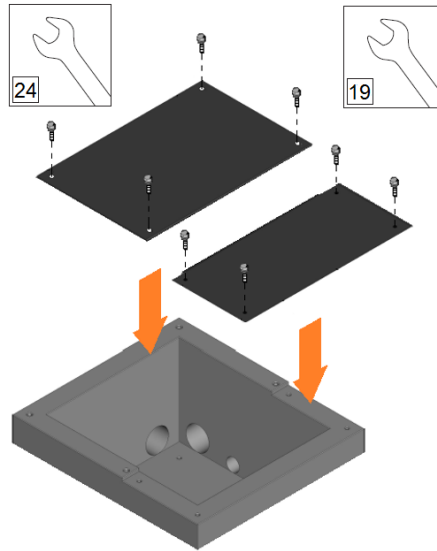

12. Secure the top cover plate with M16 bolts (4x) and the front cover plate with M12 bolts (4x).

	WARNING
	<p>These cover plates are required to prevent people from falling into the foundation.</p>

13. Fill the open space in the ground around the foundation and the channels for the conduits with filling material (e.g. sand). Filling material is packed 2 – 3 times with a packing machine until the desired ground level is obtained. Avoid having filling material inside the foundation.

4.2.3. Workflow with metal frame foundation

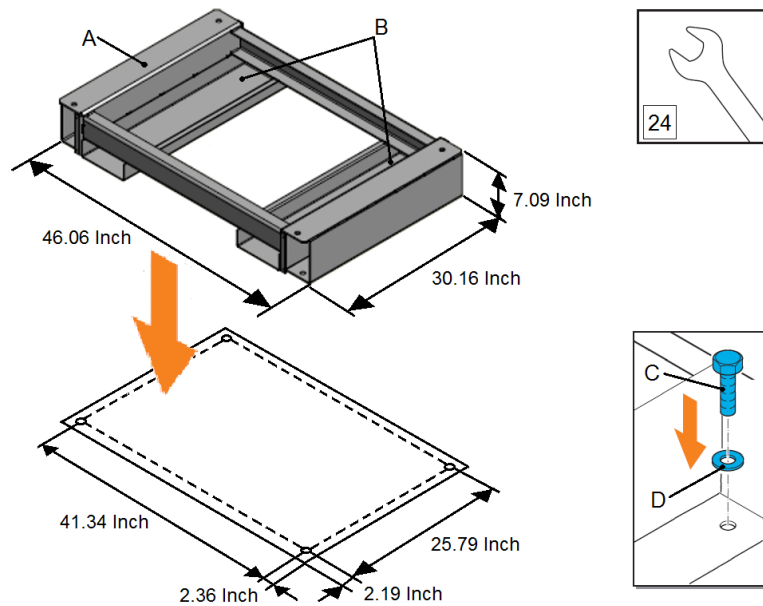

1. Place the frame (A) in the desired position and mark the position of the holes for drilling.

NOTICE	
	<p>The hole distance of 25.79 Inch on either side of the metal frame foundation is not equal to the hole distance (26.77 Inch) from the HVC 150(S) cabinet. See also the mechanical drawing in Appendix D <i>Dimensions Metal Foundation Power Cabinet</i> on page 107.</p>



2. Remove the frame.
3. Drill and tap holes at the marked positions. The holes must be suitable for bolt size M16.
4. Route the cables tray through one of the cable openings (B).
5. Align the frame (A) with the tapped holes.
6. Insert the bolts (C) fitted with the washers (D) into the holes (4x).
7. Tighten the bolts.
8. Route the AC power cable through the left cable opening (B). Make sure that a cable length of 39.37 Inch is available above the floor for internal routing in the cabinet.

NOTICE	
	<p>This extra cable length is required to connect the AC power cable with the connectors in the Power Cabinet without problems.</p>

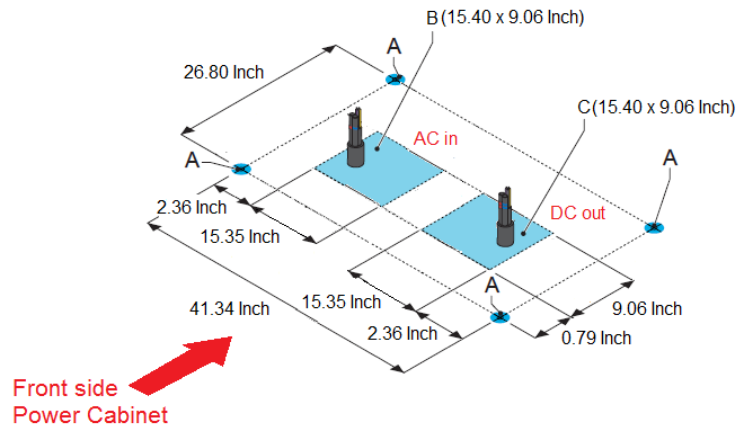
4.2.4. Workflow mounting Power Cabinet direct on a floor (footprint)



1. Drill and tap holes in the floor at the indicated positions (A). The holes must be suitable for bolt size M16.
2. Make rectangular holes on the indicated positions (B) and (C). For detail drawings bottom view of Power Cabinet see Appendix A *Dimensions Power Cabinet*.
3. Make sure that the AC power cable and other cables comes out of the floor within the marked area (B).
4. Make sure that the DC power cables come out of the floor within the marked areas (C).
5. For the AC and DC power cable, make sure that a cable length of 3.28 ft is available above the floor for internal routing in the cabinet.
6. For the other cables, make sure that a cable length of 9.84 ft is available above the floor for internal routing in the cabinet.

	NOTICE
	<p>This extra cable length is required to connect the cables with the connectors in the Power Cabinet without problems.</p>
	NOTICE
	<p>To prevent dust from entering the tapped holes, it is recommended that you cover them until you are ready to do the placement.</p>

4.3. Mounting preparation of the Depot Charge Box

4.3.1. Options

There are two options to install the Depot Charge Box:

- Soil**
 Use the concrete foundation to get a firm fixation on soil in combination with the pedestal. The concrete foundation and pedestal can be ordered separately. See section *Accessories* on Page 18.
- Wall mounting**
 The Depot Charge Box can be mounted on a solid wall.

4.3.2. Workflow with concrete foundation

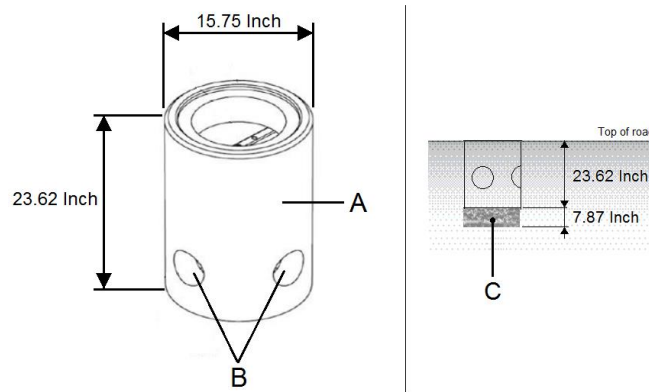

	WARNING
	<p>Make sure that personnel cannot be crushed or become trapped while moving the foundation. Be aware that the weight of the concrete foundation is about 220.46 lb.</p>
	CAUTION
	<p>Before you lower the foundation, remove sharp edges of the cable holes (B) in the foundation to protect the cables.</p>

1. Make a hole in the ground with at least a minimum depth of 31.50 Inch, shown in the figure above.
2. Fill the hole with (minimum) 7.87 Inch lean concrete (C), see figure above.
3. Make sure that the conduits are routed to one of the indicated positions (B).
4. Use the provided VP-covers for those holes on the foundation sides that will not be in use.

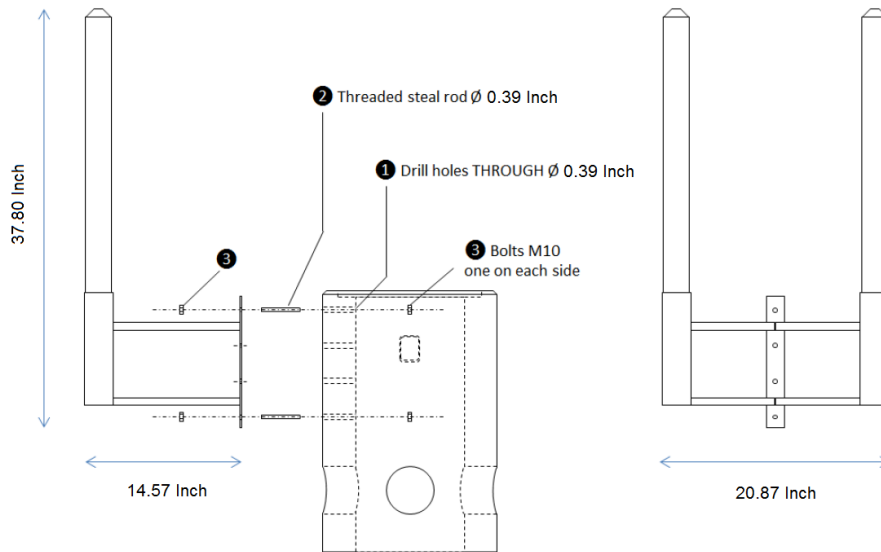

5. Additional crash protection element can be fitted to the foundation by drilling holes.

NOTICE	
	<p>Two of four holes is enough to fix the protection.</p>

6. Lower the foundation (A) into the hole. Use the metal beam inside the foundation to attach lifting devices.

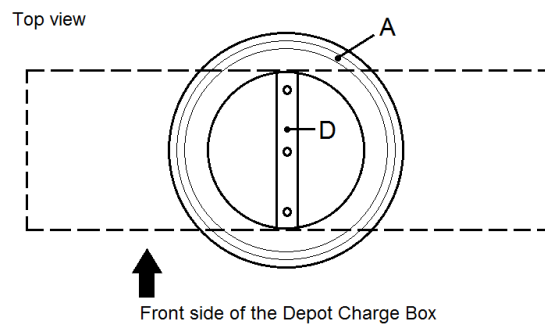

7. **IMPORTANT:** Place the foundation (A) in the correct position, which means that the beam (D) must be at right angles to the Depot Charge Box, see picture above.
8. Make sure that the front top surface of the foundation is at least 0.59 Inch above ground level (see figure above).
9. Make sure that the top surface of the foundation is leveled.
10. Route the conduits through one of the four holes (B).
11. The conduits must be installed with a curve inside the foundation in order to prevent water from entering the conduits.
12. Place the cover plates on the foundation (only needed when the foundation is temporarily not used).
13. Fill the open space in the ground around the foundation and the channels for the conduits with filling material (e.g. sand). Filling material is packed 2 – 3 times with a packing machine until the desired ground level is obtained. Avoid having filling material inside the foundation.

4.3.3. Workflow for wall mounting

Preconditions:

- Tools: mark tools, level tool, drilling machine, drill bit (Ø0.39 Inch or Ø0.30 Inch), 4x wall plugs (Ø0.39 Inch, L = 1.97 Inch)

	NOTICE
<p>For a correct operation of the Depot Charge Box, it is important that the cabinet is mounted level.</p>	

There are two options to mount the Depot Charge Box on a wall:

- Using the internal holes of the box itself on the back side.

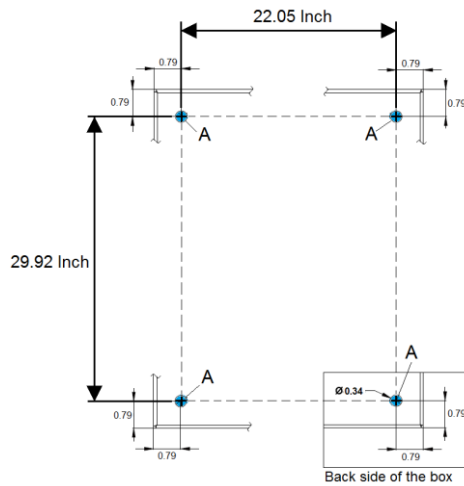

- Using external wall-mounting brackets, see section *Wall-mounting brackets for safe wall fixing* on Page 20.

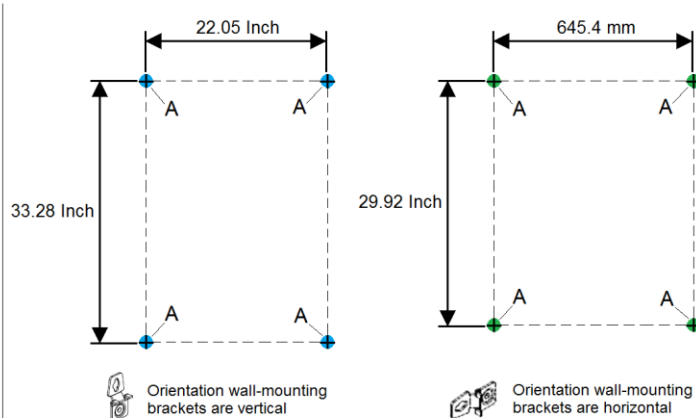
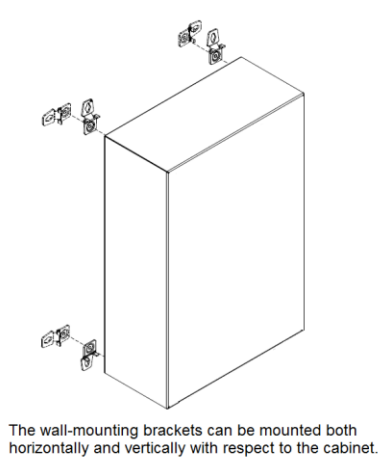



1. Drill holes in the wall at the indicated positions (A) of one of the chosen mounting options (see pictures above). For a concrete or stony wall, the holes must be suitable for a wall plug with a diameter of 0.39 Inch. For a wooden wall, the holes must be suitable for wood-wire-bolt size M8.

- In case of a concrete or stony wall, insert wall-plugs (4x) in to the holes.

	NOTICE
	<p>The activities of installing cable ducts, for the supply of cables for the Depot Charge Box, are entirely dependent of the location, and may differ per location. Due to this reason, the installation of those cable ducts our out of the scope of this Installation Guide.</p> <p>It is the responsibility of the contractor to setup a routing plan for the cable ducts, and installing this cable ducts on location.</p>

4.4. Cabling

	NOTICE
	<p>ABB recommends the use of crimped lugs for cable connections to Power Cabinet and Charge Post. Mechanical lugs can be used at the discretion of the installer and will be separately provided.</p>
	CAUTION
	<p>ABB is not responsible for damage caused to the Charger system due to the use of mechanical lugs, and is not covered by the warranty.</p>

4.4.1. Charge system configurations

There are various cabling solutions, depending on the installation situation.

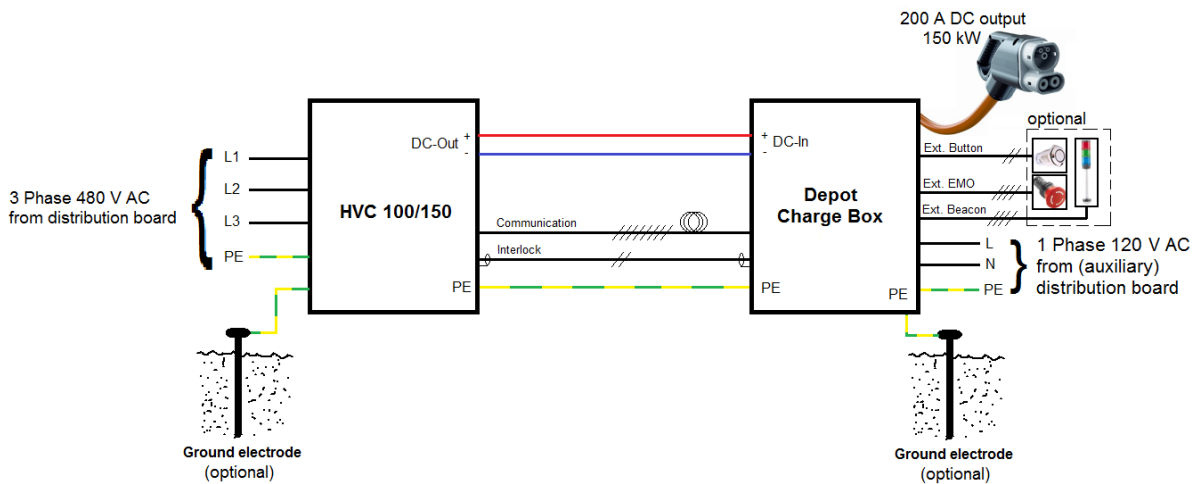

Overview electrical connections of a charge system with one Depot Charge Box

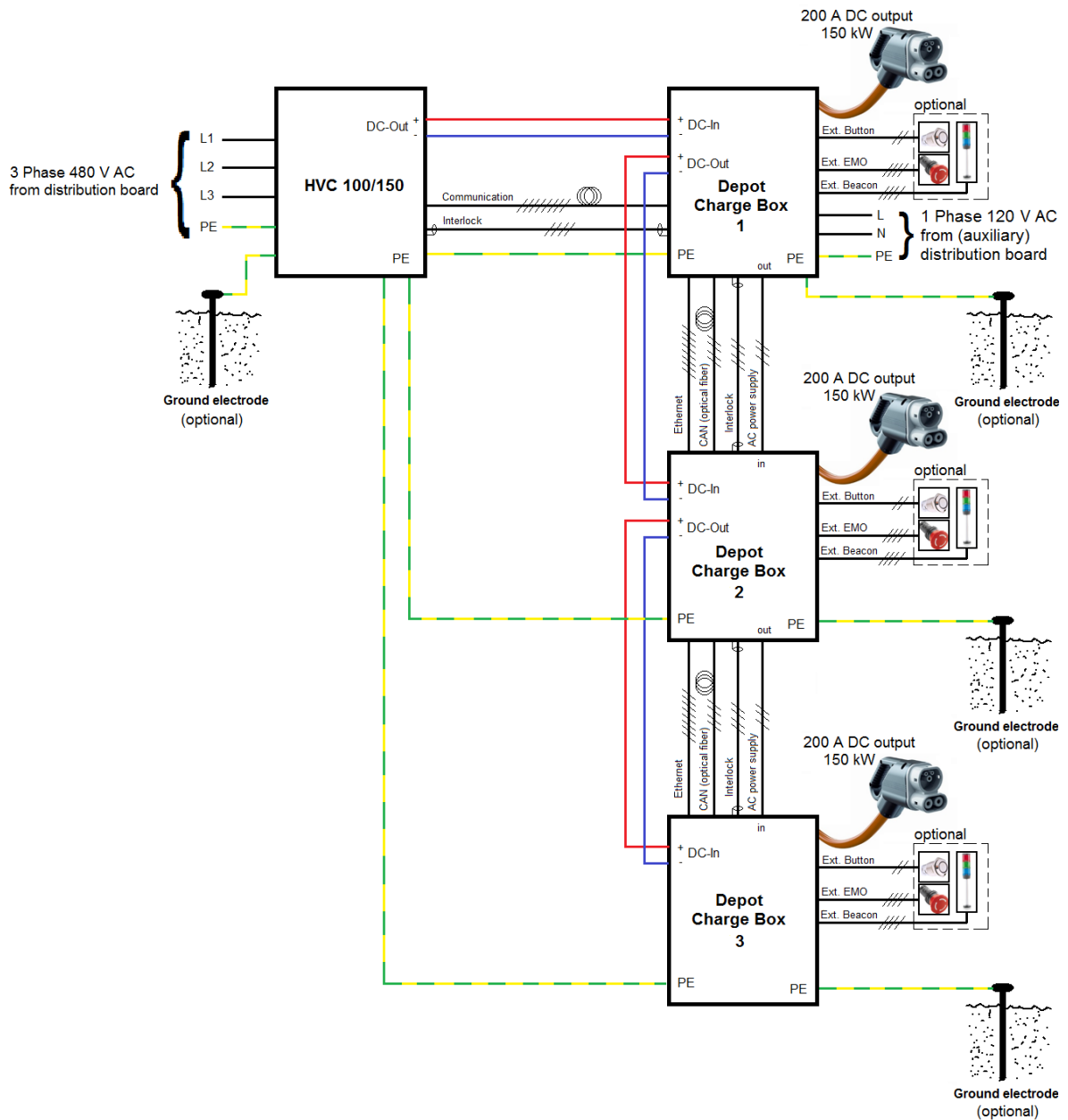

Overview electrical connections of a charge system with three Depot Charge Boxes which are individual connected with the (auxiliary) distribution board

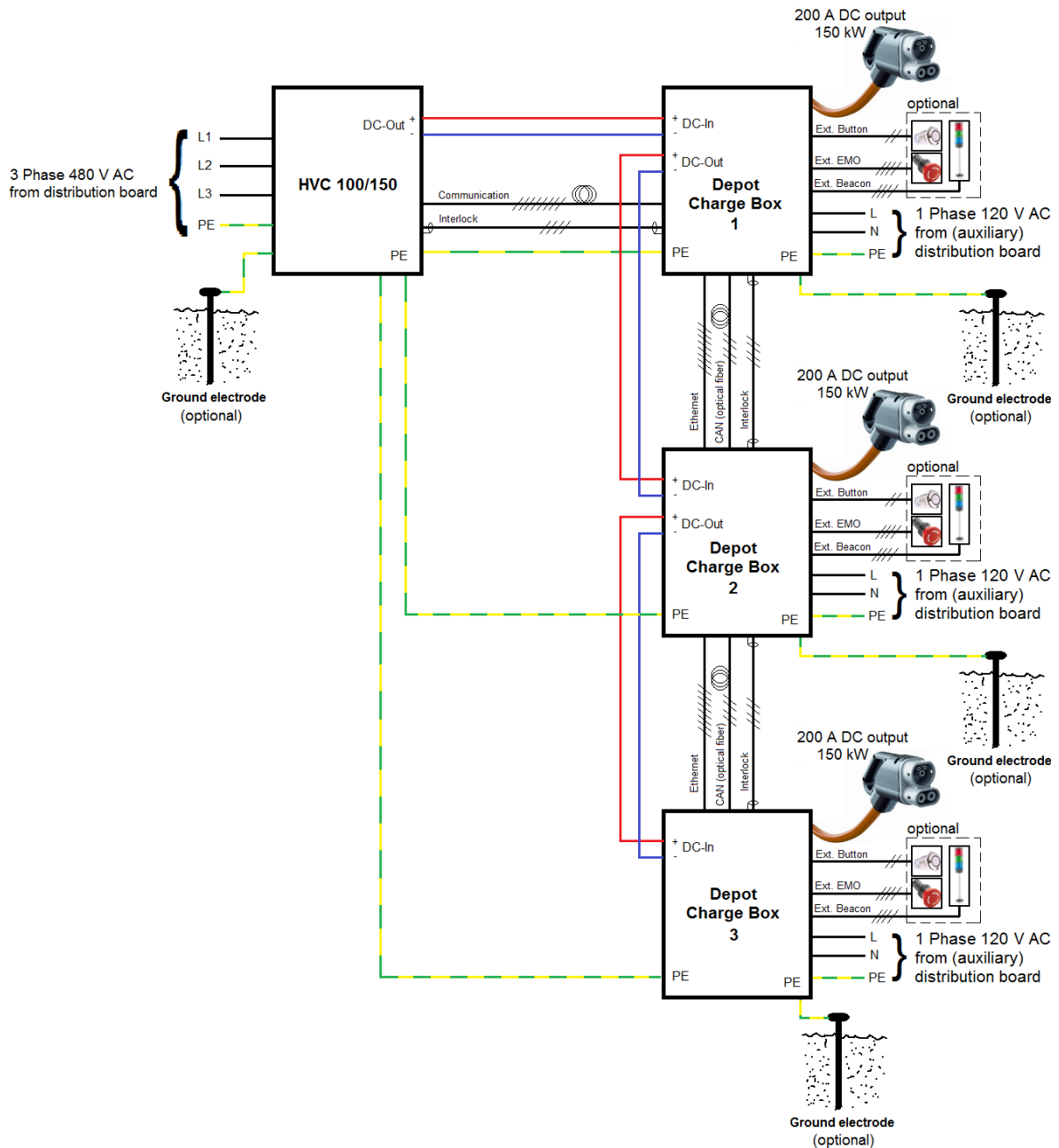

Overview electrical connections of a charge system with three Depot Charge Boxes which are daisy-chained connected with the (auxiliary) distribution board

4.4.2. AC power cable

For Power Cabinet:

- Cable type: 3P+GND (optional shielded).
- The cable shielding (if present) must be attached to the GND Rail at both ends of the cable.
- The cross section of the cable conductor must be determined by your contractor.
- The maximum cross section is 500 MCM.
- The GND conductor of the power cable must have the same cross section as the phase conductors.

For Depot Charge Box:

- Cable type: 1P+N+GND.
- The GND conductor of the power cable must have the same cross section as the phase conductors.
- 1x GND cable (optional, local GND or lighting protection, see section *Grounding of Depot Charge Boxes* on Page 46).
- This cable can be connected directly from AC distribution to each Depot Charge Box or can be routed in daisy-chain mode.

4.4.3. Cables between the Power Cabinet and the Depot Charge Box

- 2x DC power cables,
- 0 – 3x GND cable (refer to section *Grounding of Depot Charge Boxes* on Page 46),
- 1x Interlock cable,
- 1x communication cables; 8x glass fiber (4 fibers are required, 4 are for spare).

Use local regulations and datasheet of the manufacturer to determine the cross section for the DC power cables:

- The maximum cross section of the cable conductor is 350 MCM.
- Recommended cable for a 150 kW system is 4/0 AWG for a distance of 164 ft, and 350 MCM for a distance of 492 ft (both with a reinforced isolation > 5400 V DC).

4.4.4. Cables between the Depot Charge Boxes

- 1x or 2x AC auxiliary power cable (in cast daisy-chain mode is used),
- 2x DC power cables,
- 1x Interlock cable,
- 1x Ethernet cable,
- 1x Communication cables; 4x glass fiber (2 fibers are required, 2 are for spare).

	NOTICE
	<p>For detailed information about type of glass fiber cable which are needed, see <i>Communication glass fiber cable</i> on Page 20.</p>

4.4.5. Grounding of Depot Charge Boxes

- GND must be connected to each of the Depot Charge Boxes by 2 AWG cable.
- Grounding scheme is dependent on layout of specific installation site and contracted electrical company should define detailed design of grounding installation. Local legal requirements must be followed. Following options of providing GND to Depot Charge Box are proposed.
 - GND may be connected from locally available ground connection next to the Depot Charge Box
 - GND may be routed from Power Cabinet or distribution board via cable conduits. In that scenario each Depot Charge Box should have dedicated GND cable.
- There is one 2 AWG gland in Depot Charge Box used for guiding GND cable to GND connection point inside the box. Daisy-chaining of ground signal via Depot Charge Box is not allowed.

- If Depot Charge Box is installed on the pedestal or any other metal construction which must be grounded, there are two 6 AWG glands available to connect GND of Depot Charge Box enclosure to the metal frame.

NOTICE	
	<p>For the overview of the grounding of the system, see Appendix G <i>Ground overview of the system</i> on Page 110.</p>

4.4.6. Optional external interface cables

There is the possibility to connect an external Beacon light, Stop button and/or Emergency stop button (EMO) to the Depot Charge Box.

Optional external interface	Requirements
Beacon light	24VDC Three colors <u>Common plus (NPN control)</u> Max 300mA per one color
Stop button	1x NO (normally open) Contacts <1A, 24VDC is sufficient (just control) Momentary action Can be equipped with background light 24VDC
Emergency stop button (EMO)	2x NC (normally closed)

- 1x Ext. Beacon cable,
- 1x Ext. Stop button cable,
- 1x Ext. EMO cable.

4.4.7. Cable specification list

Tables below provides general specifications for the needed cables. Use these tables to select cables, taking into account local installation conditions, cable length, cable temperature rating, losses and local regulations.

AC and DC power cables

Functional description	DC Power cable	GND cable	AC auxiliary power cable
Number of cores	1	1	4
Cross section	3/0 AWG – 350 MCM	2 AWG	14 AWG
Min – Max external diameter to fit through gland	0.87 – 1.26 Inch	0.51 – 0.83 Inch	0.20 – 0.39 Inch
Shielding	No	No	No
Conductor	Tinned copper or aluminum conductor, fine wire stranded acc. to VDE 0295 cl.5/IEC Cl.5	Fine strand copper wire acc. to VDE 0295 Cl. 5/ IEC 60228 Cl. 5	Bare copper, fine wired, bunch stranded acc. to VDE 0295 Cl.5/IEC Cl.5
Insulation	Special rubber or PVC (outdoor use, UV-protected, oil resistant)	Special PVC (outdoor use, UV-protected, oil resistant)	Special PVC (outdoor use, UV-protected, oil resistant)
Minimum Nominal Voltage U _o /U	600/1000 Vac 900/1500 Vdc	600 Vac	600 Vac
Minimum Test Voltage [AC]	6 kV	4 kV	4 kV
Ambient Temperature range	-40°C to 105°C, permissible conductor operating temperature +90°C	-40°C to 105°C	-40°C to 105°C
Core identification		gn/ye or gn	Color for US Acc. to US National Electrical Code and for Canada Acc. to the CEC (Canadian Electric Code)

Data cables

Functional description	Interlock cable	Ethernet (S/FTP, CAT6/CAT5e)	Ext. Beacon cable	Ext. Stop button cable	Ext. EMO cable
Number of cores	4	8	4	2	4
Twisted pairs	Yes (2 x 2)	Yes (4 x 2)	No	No	No
Cross section	18 – 14 AWG	24 – 18 AWG	20 – 18 AWG	20 – 18 AWG	20 – 18 AWG
Min – Max external diameter to fit through gland	0.32 – 0.35 Inch	0.20 – 0.39 Inch	0.20 – 0.24 Inch	0.20 – 0.24 Inch	0.20 – 0.24 Inch
Shielding	Yes (tinned copper braid)	Yes (tinned copper braid)	No	No	No
Conductor	Fine strand copper wire	Fine strand copper wire	Fine strand copper wire	Fine strand copper wire	Fine strand copper wire
Insulation	PVC or other material that can be used outdoor and are UV-protected	PVC or other material that can be used for industrial and outdoor applications, and are UV-protected	PVC or other material that can be used for industrial and outdoor applications, and are UV-protected	PVC or other material that can be used for industrial and outdoor applications, and are UV-protected	PVC or other material that can be used for industrial and outdoor applications, and are UV-protected
Characteristic impedance	120 Ω \pm 10%	100 Ω			
Minimum Test Voltage [AC]	1.5 kV	700 V	2 kV – 4 kV	2 kV – 4 kV	2 kV – 4 kV
Ambient Temperature range	-40°C to 80°C	-40°C to 80°C	-40°C to 80°C	-40°C to 80°C	-40°C to 80°C
Core identification	Acc. to DIN 47100	TIA/EIA-568-B.1-2001 T568A	Numbering or color	Numbering or color	Numbering or color

- Important: all cables must be resistant to being placed in the ground, submerged in conduit.
- All cables must have an isolation that is self-extinguishing and flame retardant according to UL VW-1, CSA FT1.
- All cables must meet the UL and the RoHS compliance.
- The identity and/or function of the cable must be marked on every 78.74 Inch of the cable and on both ends.

4.5. Internet connection

In most cases the integrated 3G modem is used for wireless internet access. A customer SIM card is not required. If there is no 3G signal available, a standard wired internet connection is required. For this option, contact ABB Sales department (see *Contact information* on Page 13 for contact details).

5. Placement and Connection

5.1. About placement and connection

When the construction phase is finished, the HVC-C 100/150 E-Bus Charger can be placed and connected.

The planning steps for the placement and connection phase are shown in the figure below. Usually the procedure can be done within one day.

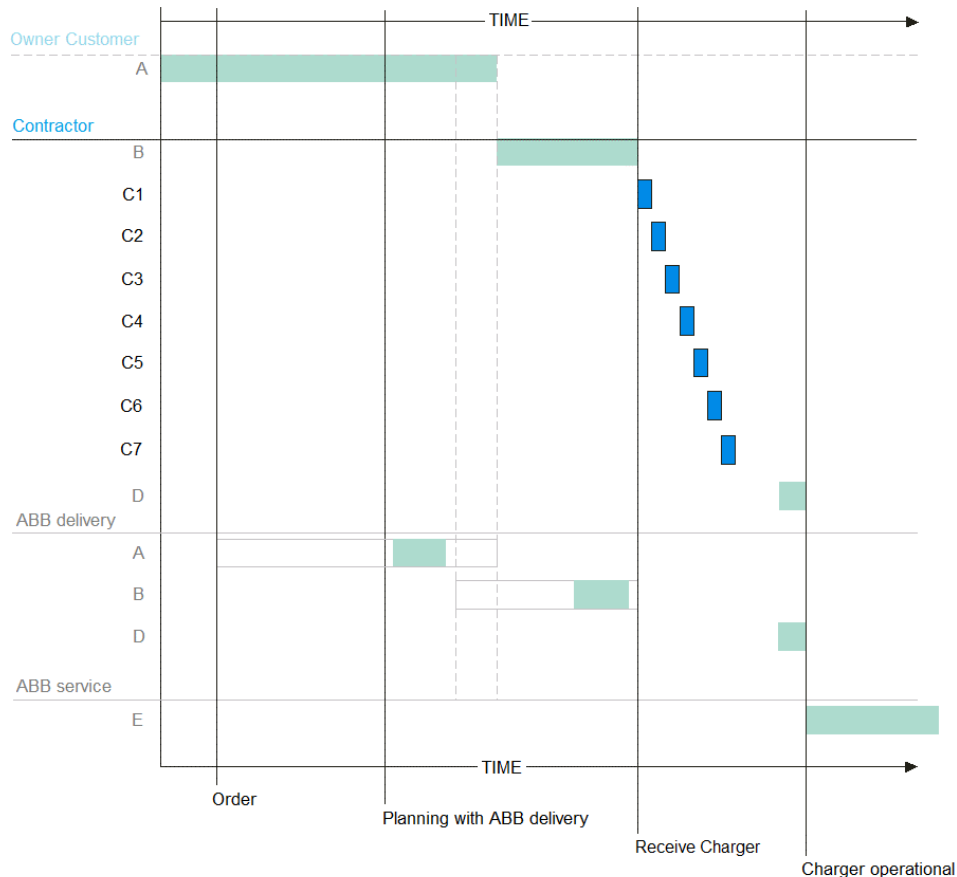

C1 *Route the cables on Page 51.*

C2 *Unpack on Page 52.*

C3 *Move Power Cabinet to position on Page 54 and Install Power Cabinet onto the foundation on Page 57.*

C4 *Connect AC power cable and GND wires Power Cabinet on Page 64, Connect the DC power cables Power Cabinets on Page 69, Connect the Interlock cable on Page 72 and Connect the communication cable Power Cabinet on Page 73.*

C5 *Unpack the Depot Charge on Page 76.*

C6 *Install Depot Charge Box onto on Page 77 or Install Depot Charge Box onto wall on Page 80.*

C7 *Connect cables Depot Charge Box on Page 82.*

5.2. Route the cables

1. Unpack the cables. See *Cabling* on Page 43 for details on which cables are needed.

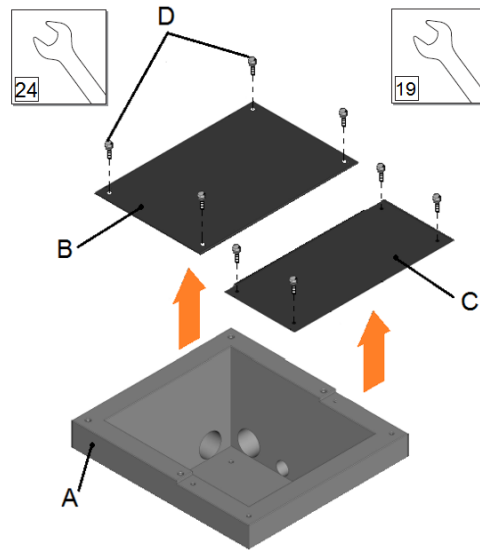

2. Remove the top cover plate (B) and the front cover plate (C) from the foundation (A) by loosen the bolts (D).
3. Put the front cover plate (C) and its bolts (D) in a safe location as it will be installed again later on.

NOTICE	
	<p>Step 2 and 3 are only applicable when the Power Cabinet is placed on a concrete foundation. The top cover plate is not needed any more after the cabinet is placed on the foundation.</p>

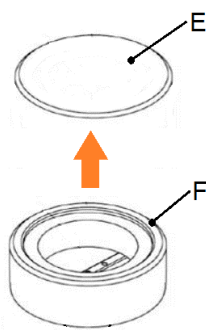

4. Remove the cover plate (E) from the foundation (F).

NOTICE	
	<p>Step 4 is only applicable when the Depot Charge Box is installed on the pedestal.</p>

5. Route the DC power cables through the cable conduit.
6. Route the AC auxiliary power, GND wire, Interlock cable and Ethernet cable (if required) through the other cable conduit.
7. Route the communication glass fiber cable through the extra 1.58 Inch cable conduit.



	CAUTION
	<p>To prevent damage to the glass fiber optic cable, a minimum of two persons is required to route the glass fiber cable through the conduit. One person for pulling, the other person to guide the glass fiber cable. Ensure that the glass fiber cable is carefully rolled out before it is pulled through the conduit, and do not use large traction forces, this can damage the glass fiber cable.</p>

8. For the DC power cables, make sure that a cable length of 39.37 Inch and 59.06 Inch is available above the surface for internal routing respectively in the Power Cabinet and in the Depot Charge Box.
9. For the other cables, make sure that a cable length of 118 Inch is available above the surface for internal routing in the Power Cabinet and Depot Charge Box.

	NOTICE
	<p>This extra cable length is required to connect the cables with the connectors in the Power Cabinet and Depot Charge Box without problems.</p>

5.3. Unpack Power Cabinet

5.3.1. Before unpacking

	NOTICE
	<p>Unloading Power Cabinet The delivery truck only unloads the pallet carrying the Power Cabinet. The delivery truck will not move the Power Cabinet to its final location. The placement of the Power Cabinet to its final location is the responsibility of the contractor. Upon request it is possible to order a truck with a crane.</p>
	CAUTION
	<p>Do not pollute the environment with plastic and cardboard packing. Depollute these things according the regional applicable regulations as well as environment-friendly.</p>

Preconditions:

- All construction work is completed.
- The product is delivered by a transport company at the confirmed date of delivery.

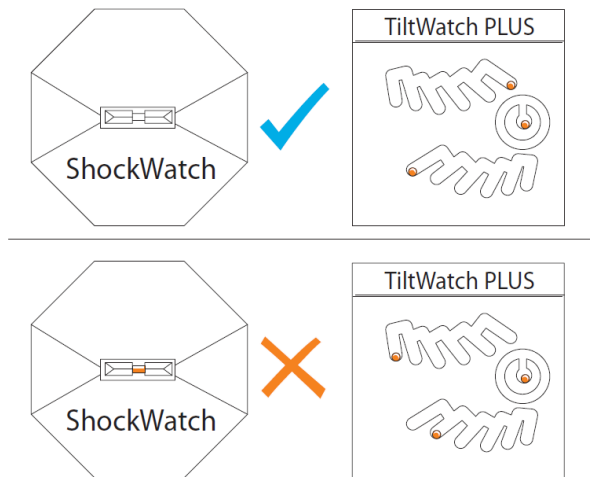

1. Make sure that the Power Cabinet has not been shaken or tilted over 30°.

5.3.2. Remove packaging

Preconditions

- Tools: spanner (size 24).

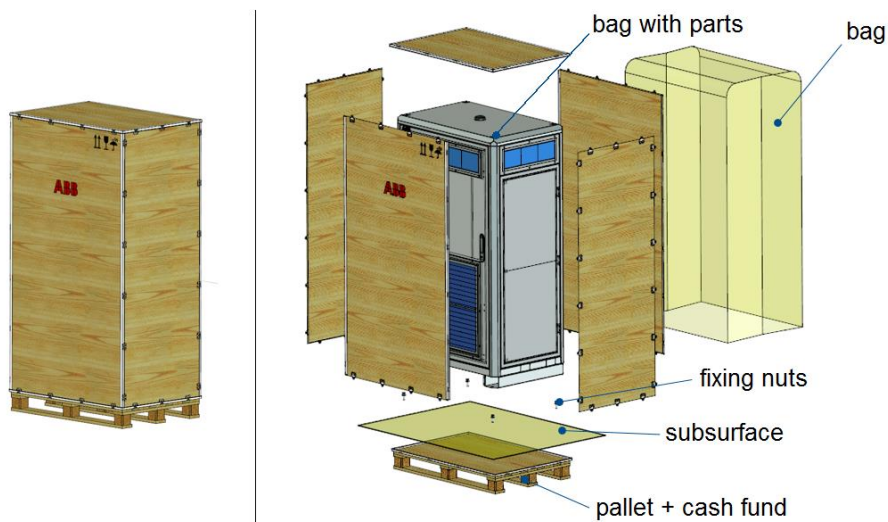

1. Remove the packaging material from the Power Cabinet.
2. Remove the bag which contain the keys, cover caps and mounting material that are attached with tape on one of the lifting eyebolt at the top of the cabinet.
3. Keep this bag with parts in a safe place.

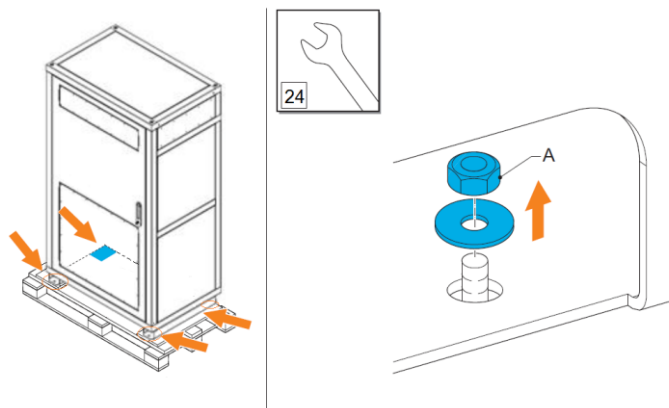

4. Remove the nuts (A) at the four corners.





5.4. Move Power Cabinet to position

There are two options to move the Power Cabinet from the delivery truck to the location.

- Use a hoist to lift the cabinet from the top. See *Move cabinet with a hoist* on Page 55.
- Use a forklift truck to lift the cabinet from the bottom. See *Move cabinet with a forklift truck* on Page 56.

Preconditions:

- All packaging material is removed from the Power Cabinet.
- The two cover plates are removed from the foundation.
- The tapped holes of the foundation are free from dust. If necessary, clean the holes with a vacuum cleaner. Use a thread tap to make sure that the bolts will go in smoothly.

	<p style="text-align: center;">DANGER</p> <p>Make sure that the main switch of the power supply group for the product is set to the OFF position. Do a voltage check to make sure that the electrical power is disconnected from the system. Secure against resetting.</p>
	<p style="text-align: center;">WARNING</p> <p>Make sure that personnel cannot be crushed or become trapped while moving the Power Cabinet.</p>
	<p style="text-align: center;">CAUTION</p> <p>Warranty Damage due to moving the Power Cabinet to its position is not covered by the warranty.</p>
	<p style="text-align: center;">CAUTION</p> <p>Do not use a compressor to clean the Power Cabinet. Use a vacuum cleaner.</p>

1. Use one of the two options to move the Power Cabinet to the foundation.
2. When the Power Cabinet is about 20 Inch above its location, continue the installation procedure with *Install Power Cabinet onto the foundation* on Page 57.

5.4.1. Move cabinet with a hoist

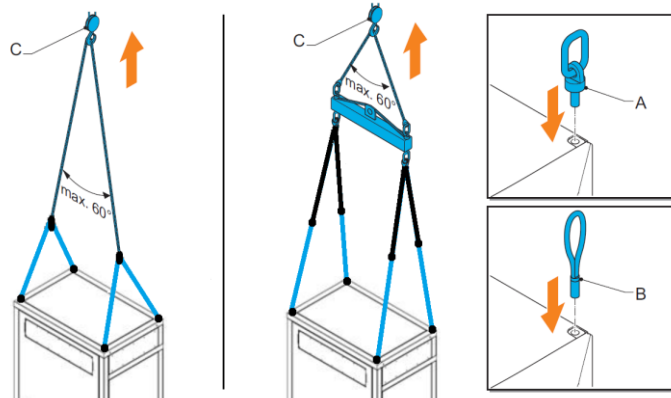

- A Swivel eye bolts (standard delivered with the cabinet)
- B Lifting loops
- C Hoisting equipment

Preconditions:

- A minimum of two persons is required: one person to operate the hoisting equipment, the other person to guide the Power Cabinet to its location.
 - Use M16 swivel eye bolts (A) or M16 bolts with lifting loops (B).
1. Insert the bolts (A) or (B) into the holes at the opposite corners of the cabinet, if not placed upon delivery.
 2. Tighten the bolts.
 3. Connect the hoisting equipment (C).

CAUTION	
	<p>Keep the hoisting angle below 60°.</p>

4. Move the Power Cabinet to the foundation.

5.4.2. Move cabinet with a forklift truck

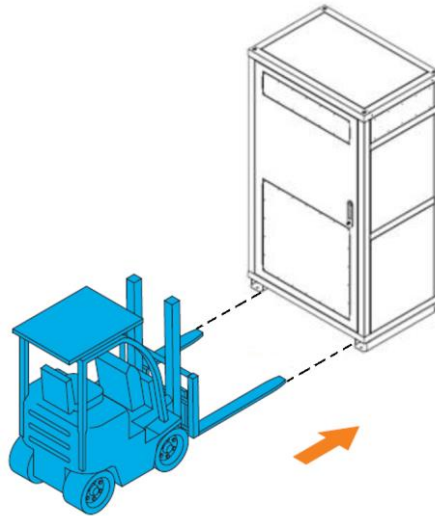

Preconditions:

- A minimum of two persons is required: one person to operate the forklift truck, the other person to guide the Power Cabinet to its location.
1. Place wooden slats with a thickness of about 0.39 to 0.59 Inch and a width equal to the width of the fork of the forklift truck on both forks.
 2. Move the forks of the forklift truck next the gaps at the rear of the Power Cabinet.
 3. Move the Power Cabinet to the foundation.



NOTICE	
	The use of the fork slides is mandatory. The distance between the outer side of the forks need to be 36.61 Inch, lifting the cabinet outside the fork slides is NOT allowed and will damage the cabinet.

5.5. Install Power Cabinet onto the foundation

5.5.1. Connect Power Cabinet to foundation

Preconditions:

- Tools: spanner (size 24).
- Cover caps (4x) that were removed from the Power Cabinet (bag with parts).
- The Power Cabinet is about 20 Inch above its location.

	<p style="text-align: center;">DANGER</p> <p>Make sure that the main switch of the power supply group for the product is set to the OFF position. Do a voltage check to make sure that the electrical power is disconnected from the system. Secure against resetting.</p>
	<p style="text-align: center;">WARNING</p> <p>Make sure that personnel cannot be crushed or become trapped while moving the Power Cabinet.</p>

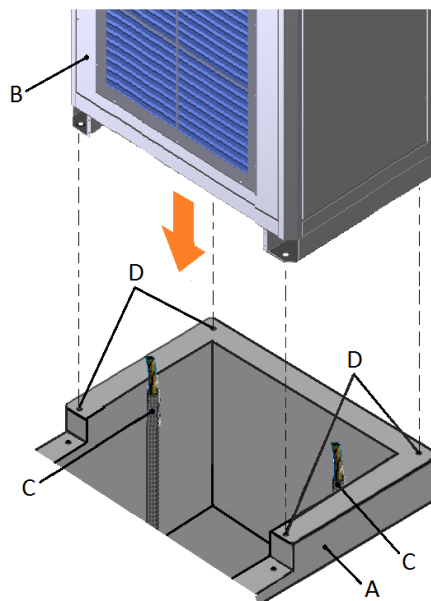

Placement on concrete foundation

- A Foundation
- B Power Cabinet
- C Cables
- D Tapped holes

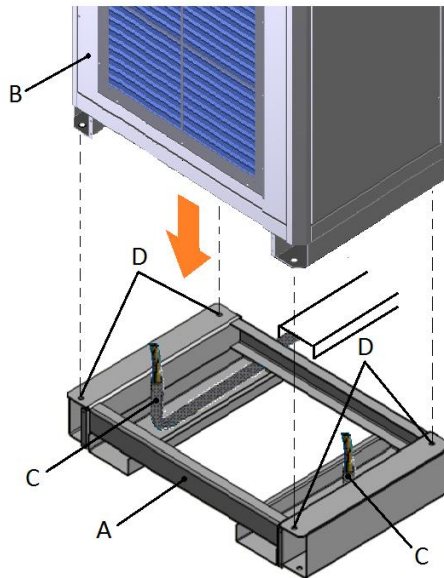

Placement on metal frame foundation

- A Foundation
- B Power Cabinet
- C Cables
- D Tapped holes

1. Carefully lower the Power Cabinet (B) onto the foundation (A).
2. Make sure that you do not trap the cables (C).
3. Make sure that the cabinet is aligned with the tapped holes (D).

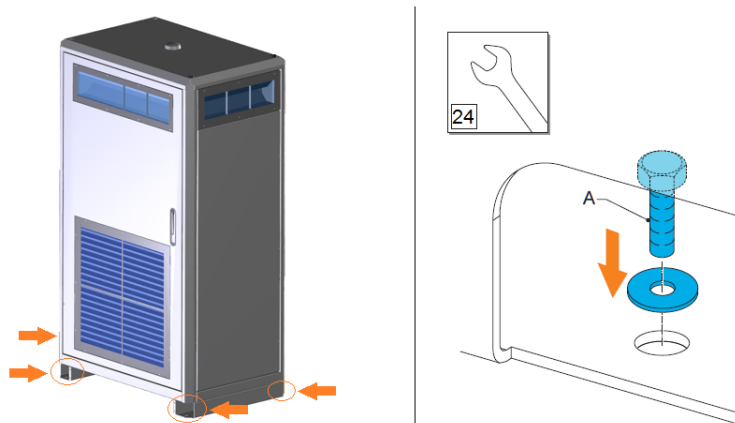

4. Insert the M16 bolts (A) fitted with the washers into the holes in the corners (4x).



NOTICE

A minimum of three M16 bolts are need to applied to securely mount the Power Cabinet onto the foundation.
In case of placing two Power Cabinets next to each other and (3.94 Inch distance) against the wall, then one Power Cabinet can be secured by three M16 bolts on to the foundation.

- Tighten the bolts with a tightening torque of 147.51 ft-lb.

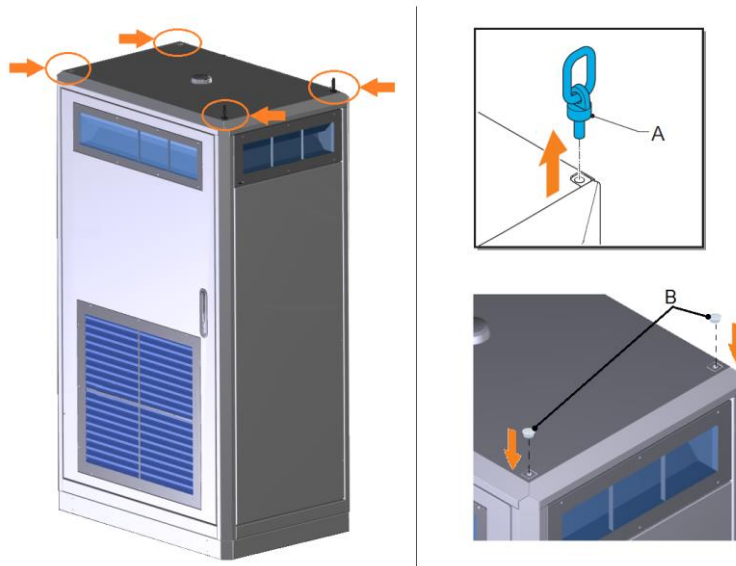

- Remove the swivel eye bolts or lifting loops (A).
- Place the cover caps (B) in the holes (4x).

5.5.2. Open the door of the Power Cabinet

Preconditions:

- Key that were removed from the Power Cabinet (bag with parts).

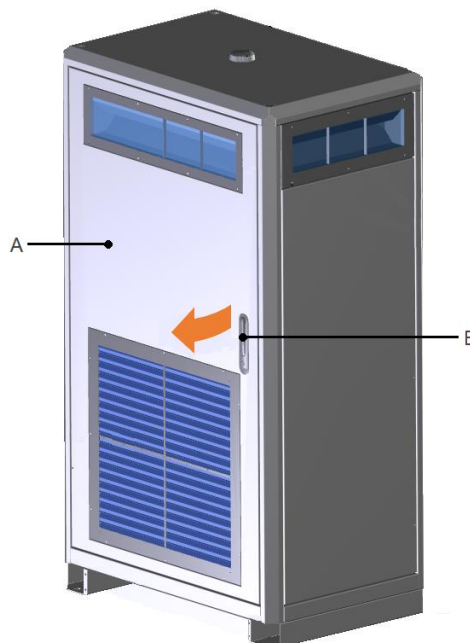

- Unlock the handle (B)
- Use the handle (B) to open the door (A).

5.5.3. Move the sliding plate of the guidance plates of the cabinet

Preconditions:

- Tools: spanner (size 13).

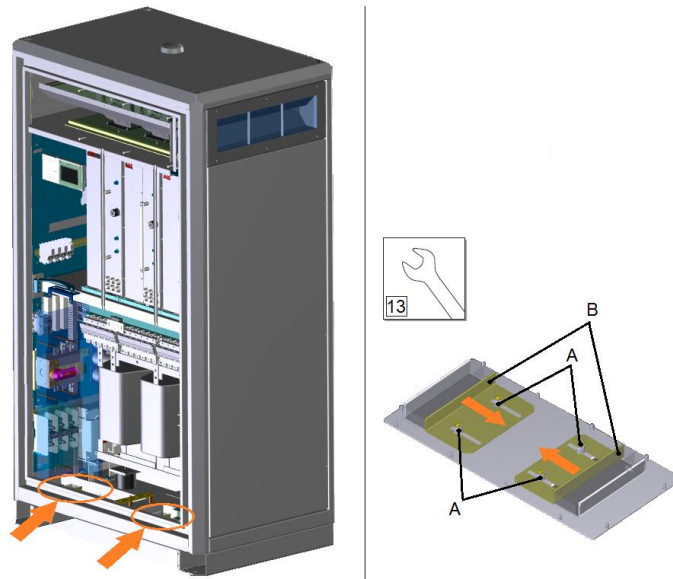

1. Loosen the bolts (A).
2. Move the sliding plate (B) of the 2 guidance plates.

5.5.4. Route cables through guidance plates

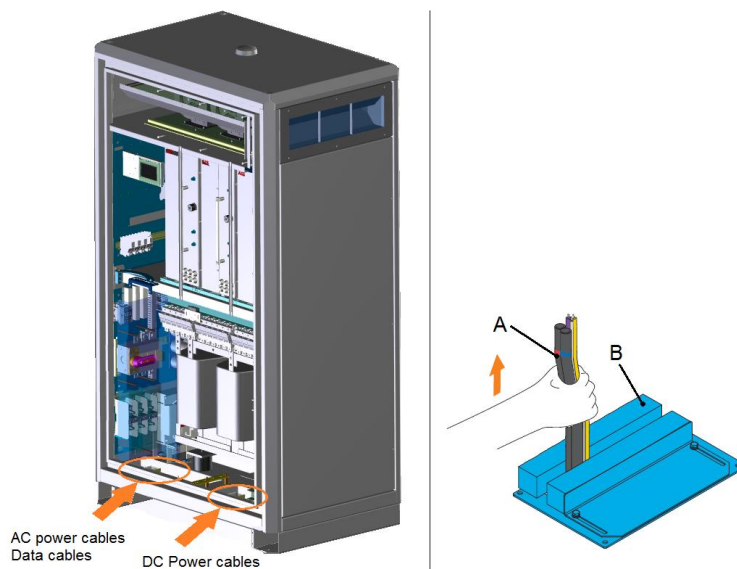

1. Route the cables (A) through the right guidance plates (B).
2. Make sure that there is sufficient cable length to reach the connectors at the top of the cabinet.

**NOTICE**

A length of 118 Inch is required, because the connection of the cables with the connectors in the Power Cabinet is at the middle of the cabinet.

5.5.5. Move sliding plates of the guidance plates of the cabinet

Preconditions:

- Tools: spanner (size 13).

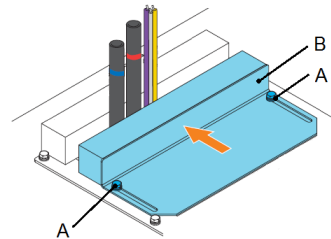
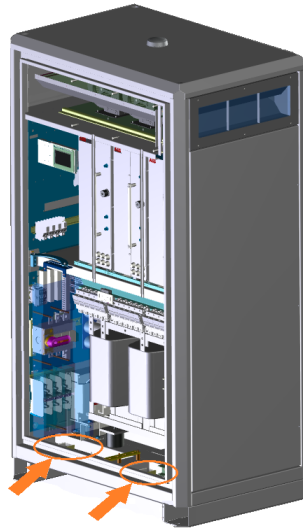

1. Move the sliding plates (B).
2. Tighten the bolts (A).

5.5.6. Install border covers of the Power Cabinet

Preconditions:

- Tools: spanner (size 8 and 10).
- M6 nuts and washers (4x) that were removed from the Power Cabinet (bag with parts).
- M5 bolts (4x) that were removed from the Power Cabinet (bag with parts).

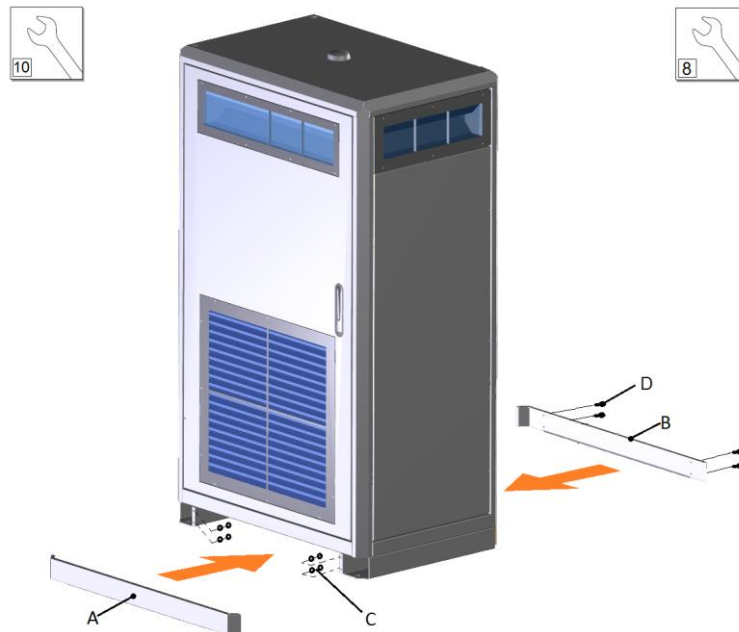

1. Put the front cover (A) against the bottom front of the Power Cabinet by aligning the four bolts at the back side of the front cover (A) with the holes in the bottom front.
2. Insert the M6 nut and washer (C) onto the bolts of the front cover (A) (4x).
3. Tighten the nuts.
4. Put the rear cover (B) against the rear front of the Power Cabinet.
5. Insert the M5 bolts (D) into the holes (4x).
6. Tighten the bolts.

5.5.7. Install border covers of metal frame foundation

NOTICE	
	<p>Only applicable when the Power Cabinet is placed on a metal frame foundation. The supplied front and rear cover on the Power Cabinet are not used in this case.</p>

Preconditions:

- Tools: spanner (size 8)

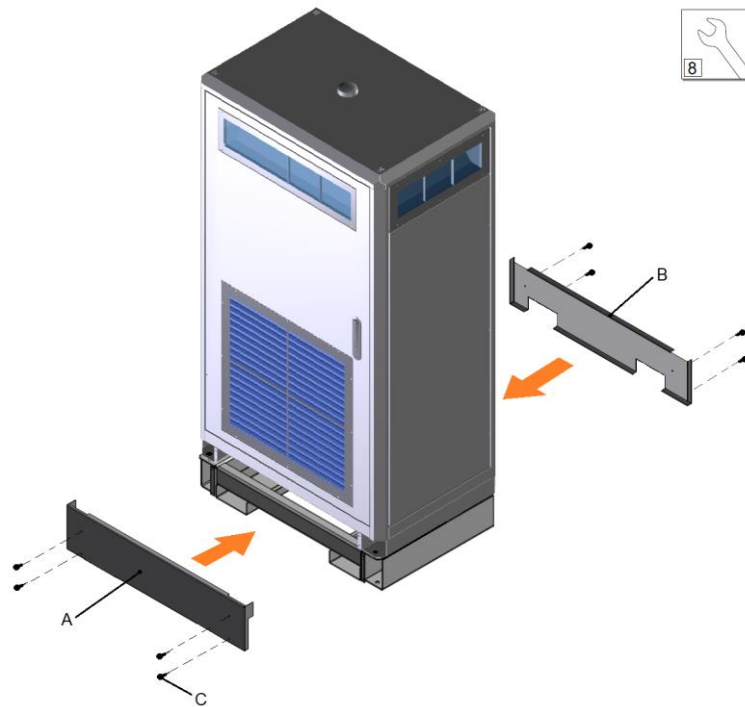

1. Put the front border cover (A) against the bottom front of the Power Cabinet.
2. Put the rear border cover (B) against the rear front of the Power Cabinet.
3. Insert the M5 bolts (C) into the holes (8x).
4. Tighten the bolts.

5.5.8. Install front cover plate on foundation

	NOTICE
	Only applicable when the Power Cabinet is placed on a concrete foundation.

Preconditions:

- Tools: spanner (size 19)

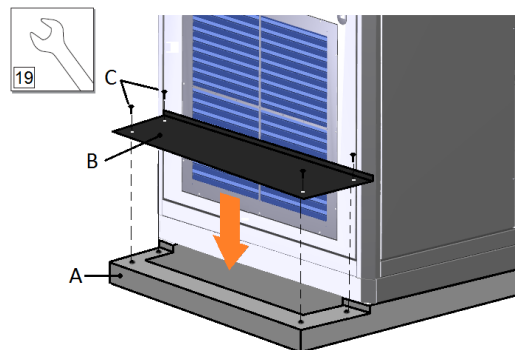

1. Place the front cover plate (B) on the foundation (A).
2. Make sure that the front cover plate (B) is aligned with the tapped holes within the foundation.

3. Insert the M12 bolts (C) into the holes (4x).
4. Tighten the bolts.

5.6. Connect AC power cable and GND wires Power Cabinet

5.6.1. Remove the protection covers

Preconditions:

- Tools: cross-head screwdriver

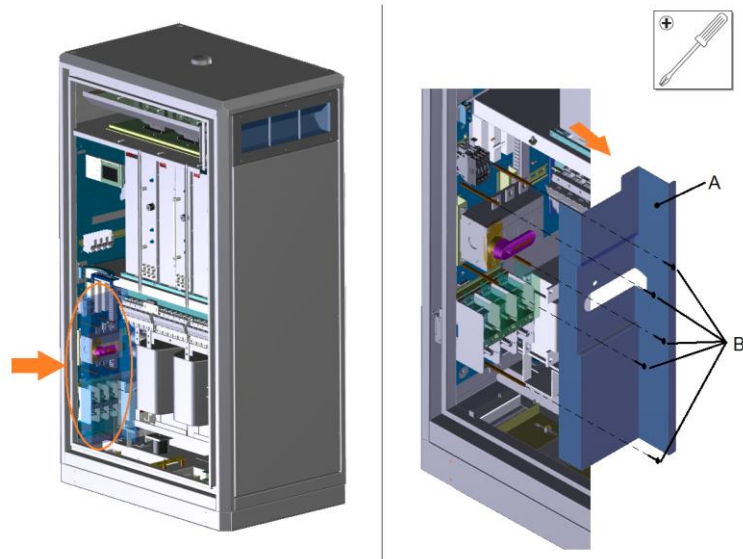

1. Remove the protection plate (A) by loosening the screws (B).
2. Put the protection plate and screws in a safe location as it will be installed again later on.

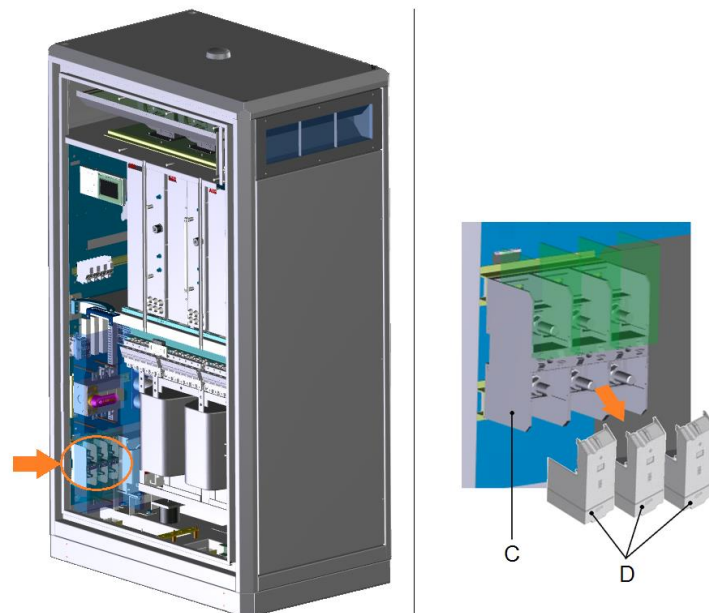

3. Remove the 3 protection covers (D) from the connector blocks (C).
4. Put the protection covers in a safe location as it will be installed again later on.

5.6.2. Connect the GND wire of the AC power cable

Preconditions:

- Tools: wire cutter, wire stripper pliers, wire-end ring, spanner (size 19), torque wrench (size 19).

	DANGER
<p>Make sure that the main switch of the power supply group for the product is set to the OFF position. Do a voltage check to make sure that the electrical power is disconnected from the system. Secure against resetting.</p>	

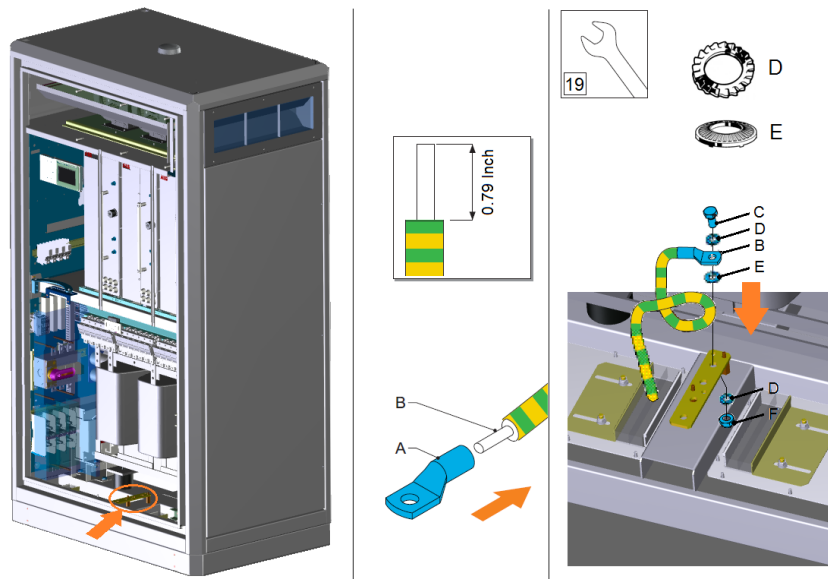

1. Make a loop in the GND wire.

	NOTICE
<p>For safety, it is recommended to make a loop in the GND wire so it is longer than the phase wires. This loop makes sure that the GND wire is not the first wire that is disconnected if the Power Cabinet is moved by a collision.</p>	

2. Cut the GND wire of the AC power cable to the correct length to reach the GND rail. Do not make the wire routing too tight, or too loose.
3. Strip 0.79 Inch of the insulation from the end of the GND wire.
4. Attach a wire end ring (A) to the end of the GND wire (B).
5. Remove the M12 bolt, nut and washers from the GND rail.
6. Fit the bolt (C) with toothed washer (D), the GND wire (B) and the contact washer (E).
7. Insert the bolt fitted with the GND wire into the GND rail.
8. Screw from the bottom of the GND rail a toothed washer (D) and a nut (F) on the bolt (C)
9. Tighten the bolt/nut connection with a tightening torque of 22 ft-lb.

5.6.3. Connect the AC power cable

Preconditions:

- Tools: wire cutter, wire stripper pliers, spanner (size 19), torque wrench (size 19).

	DANGER
<p>Make sure that the main switch of the power supply group for the product is set to the OFF position. Do a voltage check to make sure that the electrical power is disconnected from the system. Secure against resetting.</p>	

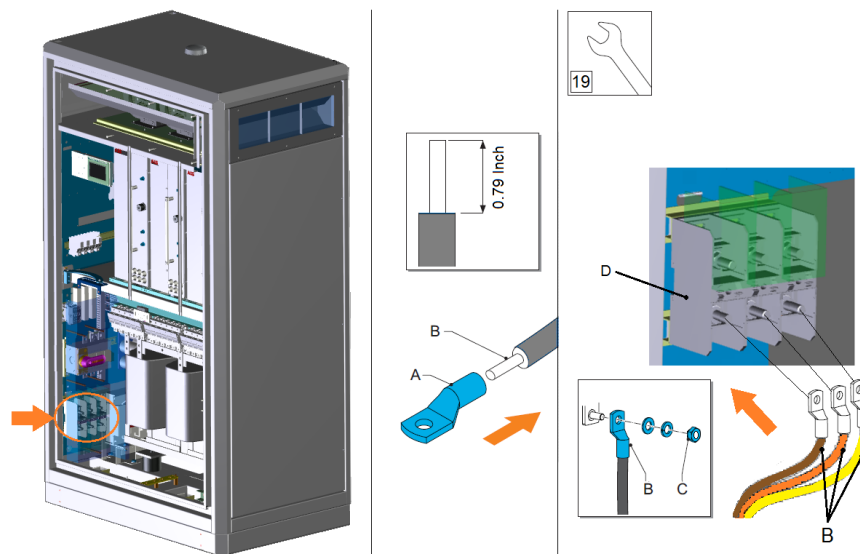

- Cut the wires of the AC power cable to the correct lengths to reach the connectors. Do not make the wire routing too tight, or too loose.
- Strip 0.79 Inch of the insulation from the ends of the wires (B).
- Attach wire end rings (A) at the end of the wires.
- Remove the nuts and washers (C) from the bolts (M12) of connector block (D).
- Insert the 3 wires (B) with the nuts and washers onto the bolts of connector block (D).
 - From left to right:
 - L1 (brown),
 - L2 (orange),
 - L3 (yellow).
- Tighten the nuts (C) with a tightening torque of 22 ft-lb.

5.6.4. Install the protection covers

Preconditions:

- Tools: cross-head screwdriver

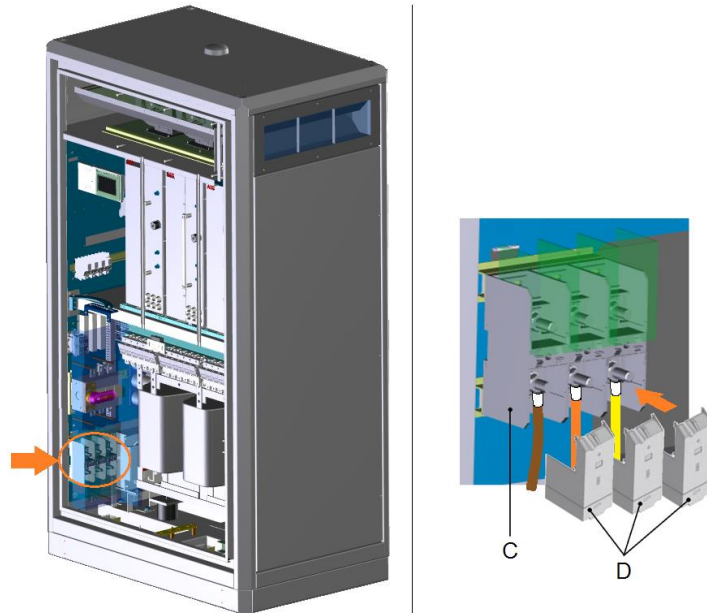

1. Take the 3 protection covers that was removed in *Remove the protection covers* on Page 64.
2. Place the protection covers (D) back on the connector blocks (C).

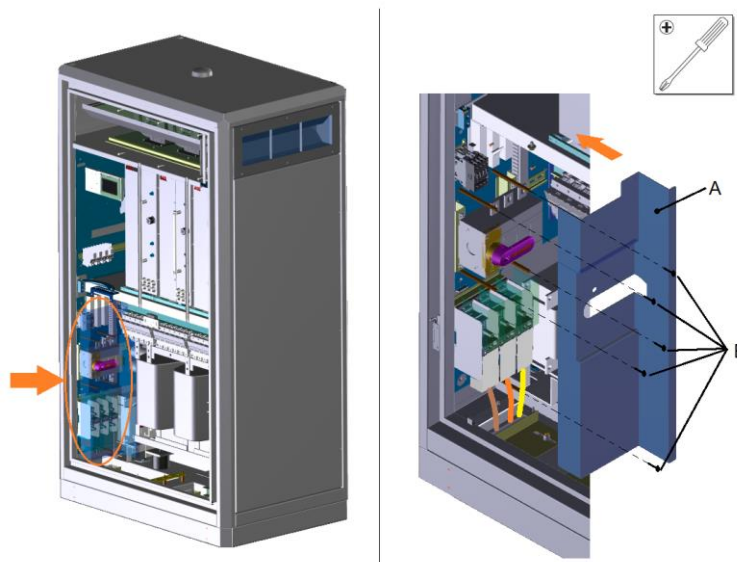

3. Take the protection plate and the screws that were removed in *Remove the protection covers* on Page 64.
4. Place the protection plate (A) back over the main switch and connector blocks and secure the plate by the screws (B).

WARNING	
	<p>Leave the main switch switched off. The Power Cabinet is not ready for use yet. If there is no appointment for commissioning yet, contact the ABB Delivery department to make an appointment for commissioning. See <i>Contact information</i> on Page 13 for contact details.</p>

5.6.5. Install lightning protection (optional)

Preconditions:

- Tools: wire cutter, wire stripper pliers, wire-end ring, spanner (size 19), torque wrench (size 19).

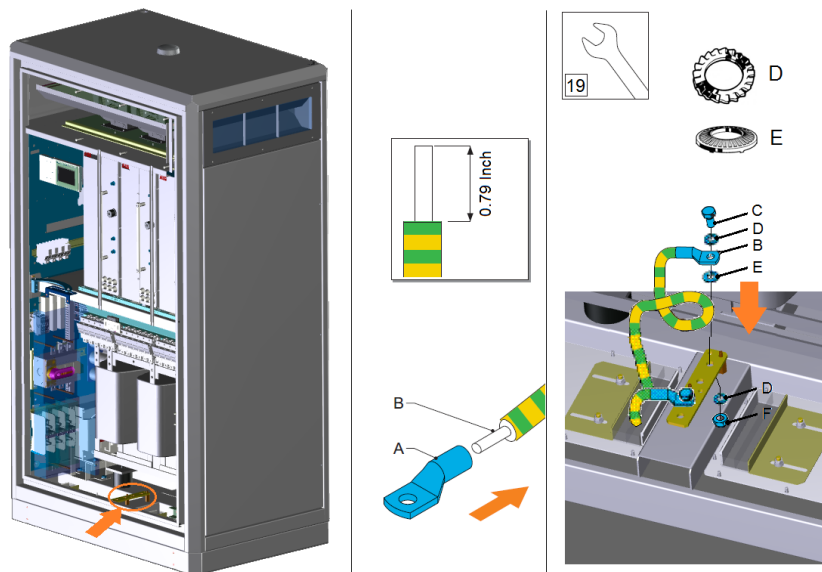

- Cut the wire of the lightning protection cable to the correct length to reach the GND rail. Do not make the wire routing too tight, or too loose.
- Strip 0.79 Inch of the insulation from the end of the wire.
- Attach a wire end ring (A) to the end of the lightning protection wire (B).
- Remove the M12 bolt, nut and washers from the GND rail.
- Fit the bolt (C) with toothed washer (D), the lightning protection wire (B) and the contact washer (E).
- Insert the bolt fitted with washers and the lightning protection wire into the GND rail.
- Screw from the bottom of the GND rail a toothed washer (D) and a nut (F) on the bolt (C)
- Tighten the bolt/nut connection with a tightening torque of 22 ft-lb.

5.6.6. Connect the GND wire(s) to the Depot Charge Box(s)

Preconditions:

- Tools: wire cutter, wire stripper pliers, wire-end ring, spanner (size 19), torque wrench (size 19).

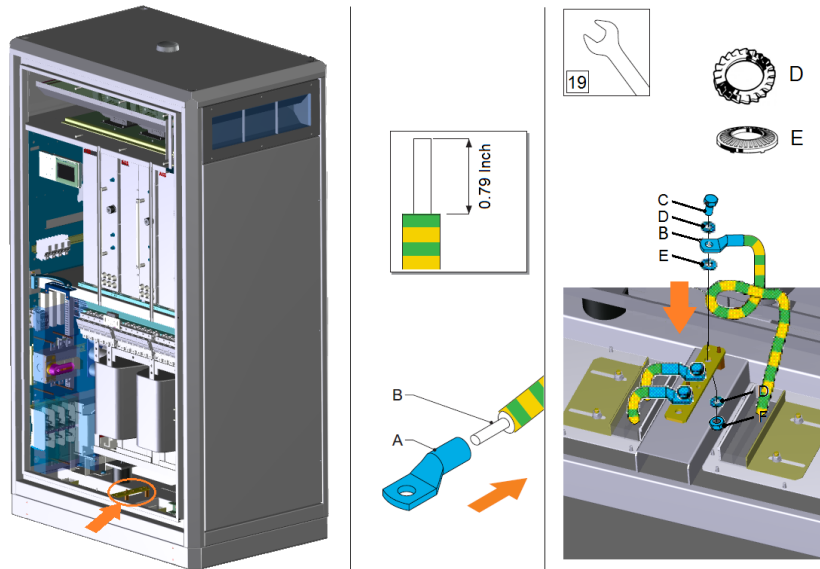

1. Cut the GND wire of the power cable to the correct length to reach the GND rail. Do not make the wire routing too tight, or too loose.
2. Strip 0.79 Inch of the insulation from the end of the GND wire.
3. Attach a wire end ring (A) to the end of the GND wire (B).
4. Remove the M12 bolt, nut and washers from the GND rail.
5. Fit the bolt (C) with toothed washer (D), the GND wire (B) and the contact washer (E).
6. Insert the bolt fitted with the GND wire into the GND rail.
7. Screw from the bottom of the GND rail a toothed washer (D) and a nut (F) on the bolt (C)
8. Tighten the bolt/nut connection with a tightening torque of 22 ft-lb.

5.7. Connect the DC power cables Power Cabinets

Preconditions:

- Tools: wire cutter, wire stripper pliers, cable lugs (eg. Cembre A48-M12 cable lug, when using 500 MCM cables) (6x), spanner (size 19), torque wrench (size 19), cross-head screwdriver.

	DANGER
<p>Make sure that the main switch of the power supply group for the product is set to the OFF position. Do a voltage check to make sure that the electrical power is disconnected from the system. Secure against resetting.</p>	

5.7.1. Remove the protection cover

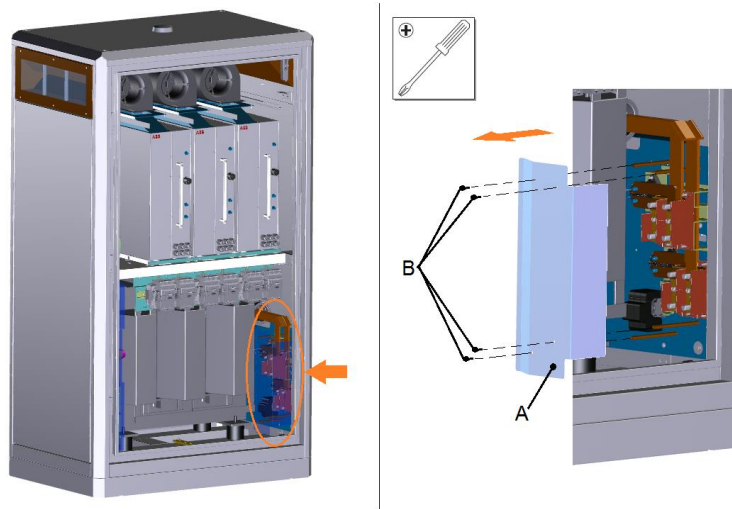

1. Remove the protection plate (A) by loosening the screws (B) (4x).
2. Put the protection plate and screws in a safe location as it will be installed again later on.

5.7.2. Connect the DC power cables

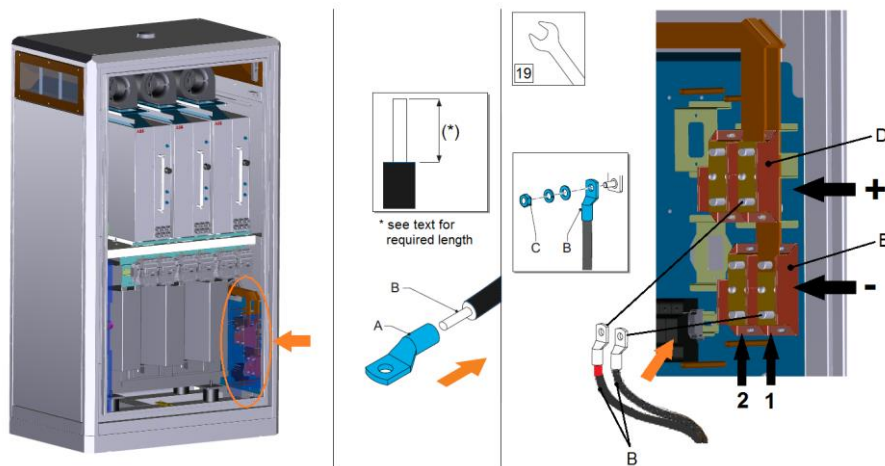

1. Cut the wires of the DC power cable to the correct lengths to reach the connectors. Do not make the wire routing too tight, or too loose.
2. Strip the insulation on the required length specified by the used lug from the end of the wire (B).
3. Attach cable lug (A) at the end of the wires.
4. Remove the nuts and washers (C) from the bolts (M12) of connector block (D) and (E).
5. Insert the DC+ wire (marked by red heat-shrink) with the nuts and washers onto the bolts of pin 1 of the connector block (D).
6. Insert the DC- wire with the nuts and washers onto the bolts of pin 1 of the connector block (E).
7. Tighten the nuts (C) with a tightening torque of 22 ft-lb.

5.7.3. Install the protection cover

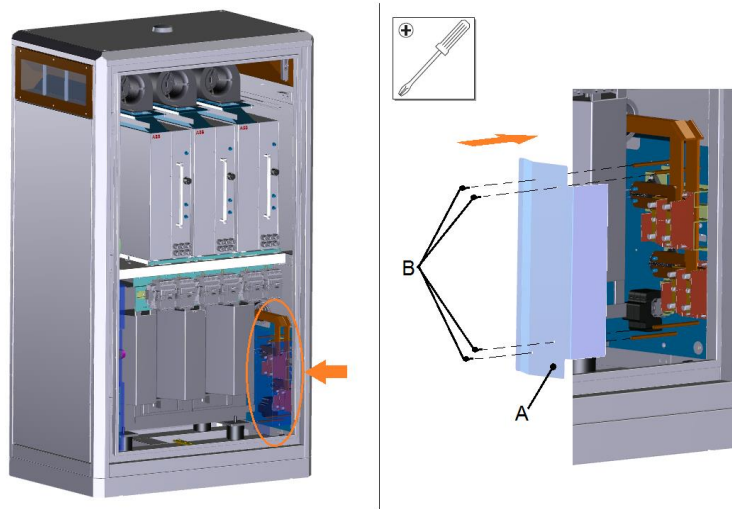

1. Take the protection plate that was removed in *Remove the protection cover* on Page 70.
2. Place the protection plate (A) back over the DC connector blocks and secure the plate by the screws (B) (4x).

5.8. Interlock cable Power Cabinet

Preconditions:

- Tools: wire cutter, wire stripper pliers, screwdriver, ferrules, crimp pliers.

	DANGER
<p>Make sure that the main switch of the power supply group for the product is set to the OFF position. Do a voltage check to make sure that the electrical power is disconnected from the system. Secure against resetting.</p>	

5.8.1. Route the cable to the terminal blocks

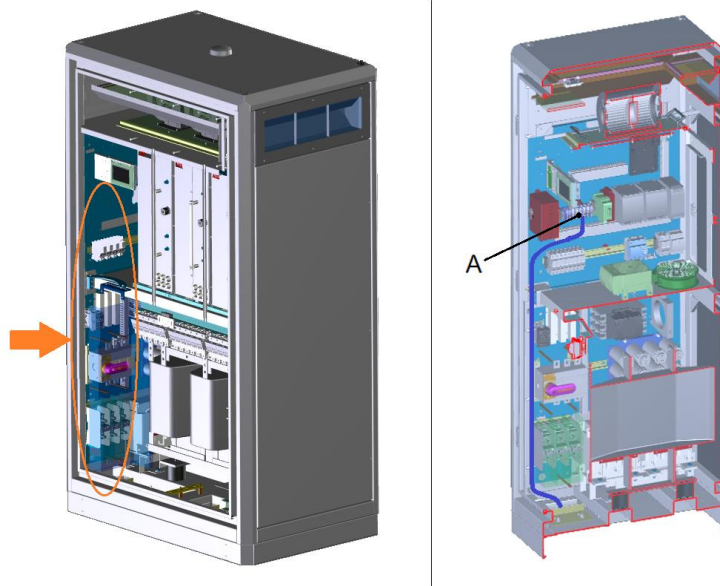

Preferred cable route

Route the Interlock cable to the terminal block (A). Refer to the figure for the preferred cable route inside the cabinet.

5.8.2. Connect the Interlock cable

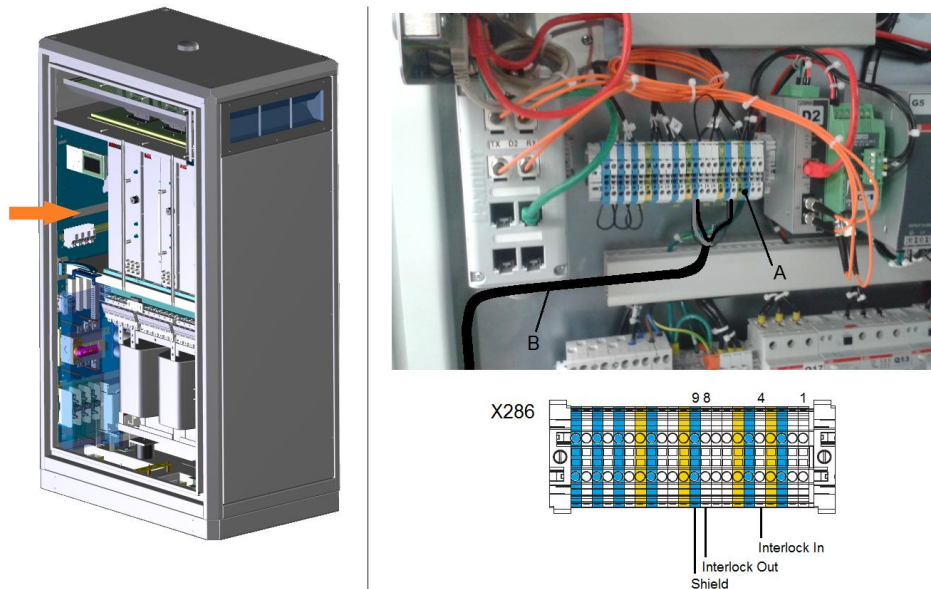

- A Terminal block
- B Interlock cable

1. Move the cable towards the terminal block (A).
2. Strip 0.43 Inch of the insulation from the ends of **only the White and Brown wire!**
3. Crimp a ferrule onto the end of the White and Brown wire.
4. Ensure that the unused wires, the Green and Yellow wire, are protected so that they cannot touch metal parts.
5. Loosen the connector screws.

6. Insert the wires into the connectors, see table below:

Functional description	Connector	Wire number
Interlock In	X286-4	Brown
Interlock Out	X286-8	White
Interlock GND	X286-9	Shield

See also Appendix H *Signal connection diagram*.

7. Tighten the connector screws with a tightening torque of 1.0 ft-lb.

5.9. Connect the communication cable Power Cabinet

Preconditions:

- Tools: tak-ty or ty-raps

5.9.1. Route the cable to the terminal blocks

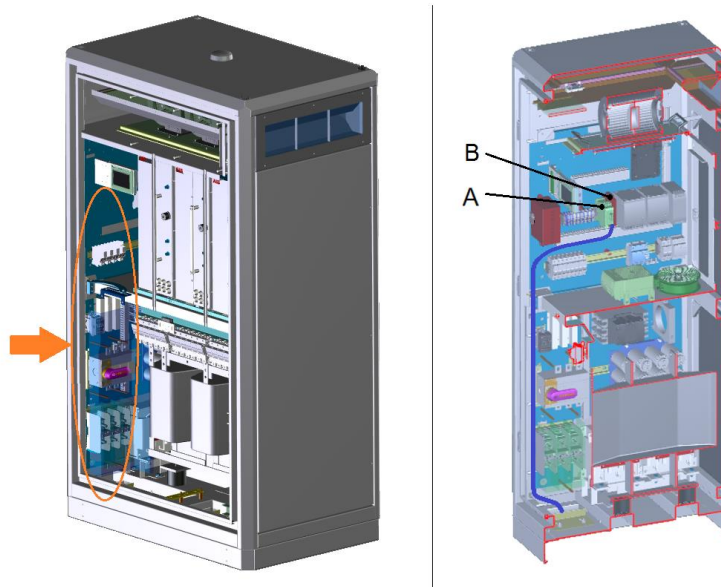

Preferred cable route

Route the communication fiber cable to module D1 (B) and D2 (A). Refer to the figure for the preferred cable route inside the cabinet.

5.9.2. Connect the communication fiber cables

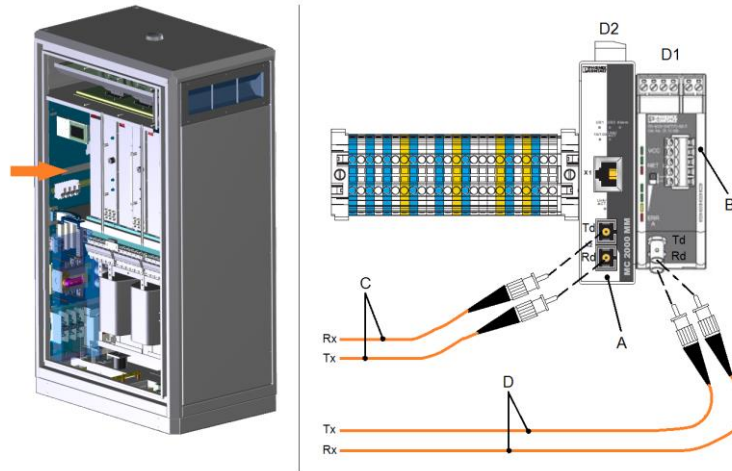

1. Remove the protection covers from the optical connectors.
2. Connect the two Ethernet fiber cables (C) onto the module D2 (A):
 - Rx (Optical 2) with Td D2;
 - Tx (Optical 1) with Rd D2.
3. Connect the two CAN bus fiber cables (D) onto module D1 (B):
 - Rx (Optical 2) with Td D1;
 - Tx (Optical 1) with Rd D1.

NOTICE	
	<p>Four fiber cables are not connected. Those fiber cables are meant for spare.</p>

4. Bind the cables together and secure the loops loosely with a piece of tak-ty or ty-rap.

CAUTION	
	<p>Make the loop bend radius of the fiber cables not smaller than 2.52 Inch, otherwise the core of the fiber cable may break.</p>

5.10. Close the door of the Power Cabinet

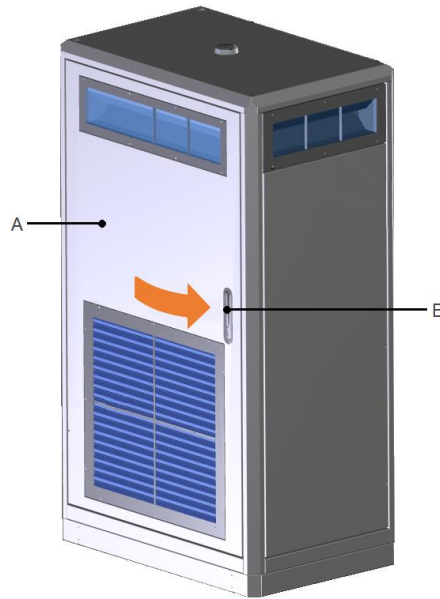

Preconditions:

- Key that were removed from the Power Cabinet

1. Close the door (A).
2. Lock the handle (B).

5.11. Unpack the Depot Charge Box

5.11.1. Before unpacking

	CAUTION
	<p>Do not pollute the environment with plastic and cardboard packing. Depollute these things according the regional applicable regulations as well as environment-friendly.</p>

Preconditions:



- All construction work is completed.
- The product is delivered by a transport company at the confirmed date of delivery.

1. Check the box for damages.

5.11.2. Remove packaging

Preconditions:

- The installation work must be carried out by at least two persons.

	WARNING
	<p>Make sure that personnel cannot be crushed or become trapped while moving the Depot Charge Box (and pedestal) out of the box.</p>
	CAUTION
	<p>Warranty Damage due to moving the Depot Charge Box and pedestal out of the box is not covered by the warranty.</p>



1. Unpack Depot Charge Box.
2. Remove the bag (B) which contain the keys, cover caps and mounting material. The bag is attached with tape to one of the cable holders (A).
3. Lift the Depot Charge Box out of the box.
4. Place the Depot Charge Box on the ground with its top facing up.
5. Remove all protective foam from the Depot Charge Box.

Next steps are only applicable when the Depot Charge Box will be installed on a pedestal.

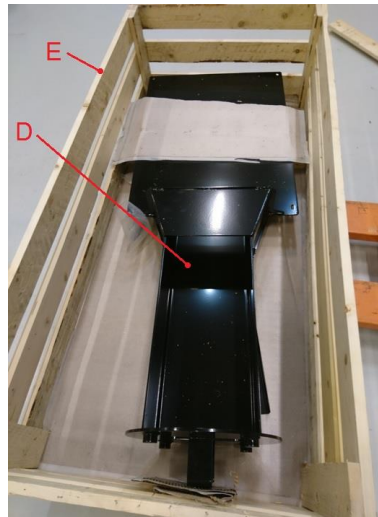

6. Unpack pedestal.
7. Remove the cover (E) from the wooden box.
8. Lift the pedestal out of the box.
9. Place the pedestal on the ground on a **protective surface** with its top facing up.

CAUTION	
	<p>To prevent damage to the paint layer of the pedestal, always place the pedestal on a protective surface that provides sufficient protection against scratches and other damage.</p> <p>ABB is not responsible for causing damage to the pedestal during unpacking of the pedestal.</p>

10. Remove all protective foam from the pedestal.

5.12. Install Depot Charge Box onto Pedestal

5.12.1. Connect Pedestal to foundation

Preconditions:

- All packaging material is removed from the Pedestal.
- A minimum of two persons is required.
- Tools: torx screwdriver (size TT20), spanner (size 19).

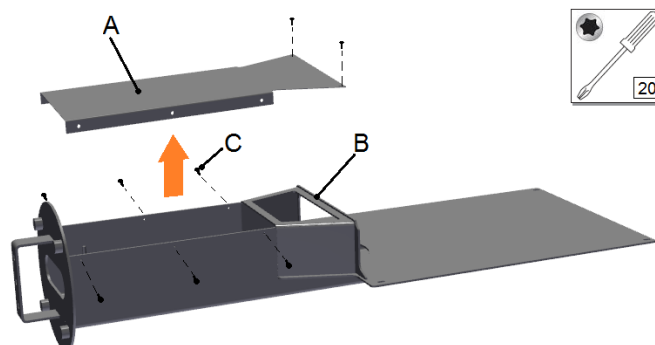

1. Remove the front cover plate (A) from the Pedestal (B) by loosen the bolts (C) (8x).

- Put the front cover plate (A) and the bolts (C) in a safe location as it will be installed again later on.

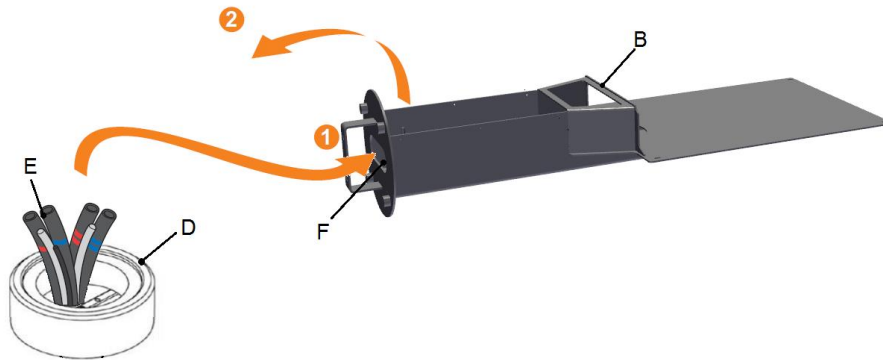

- Carefully position the Pedestal (B) next to the foundation (D).
- Pull the cables (E) through the opening (F).

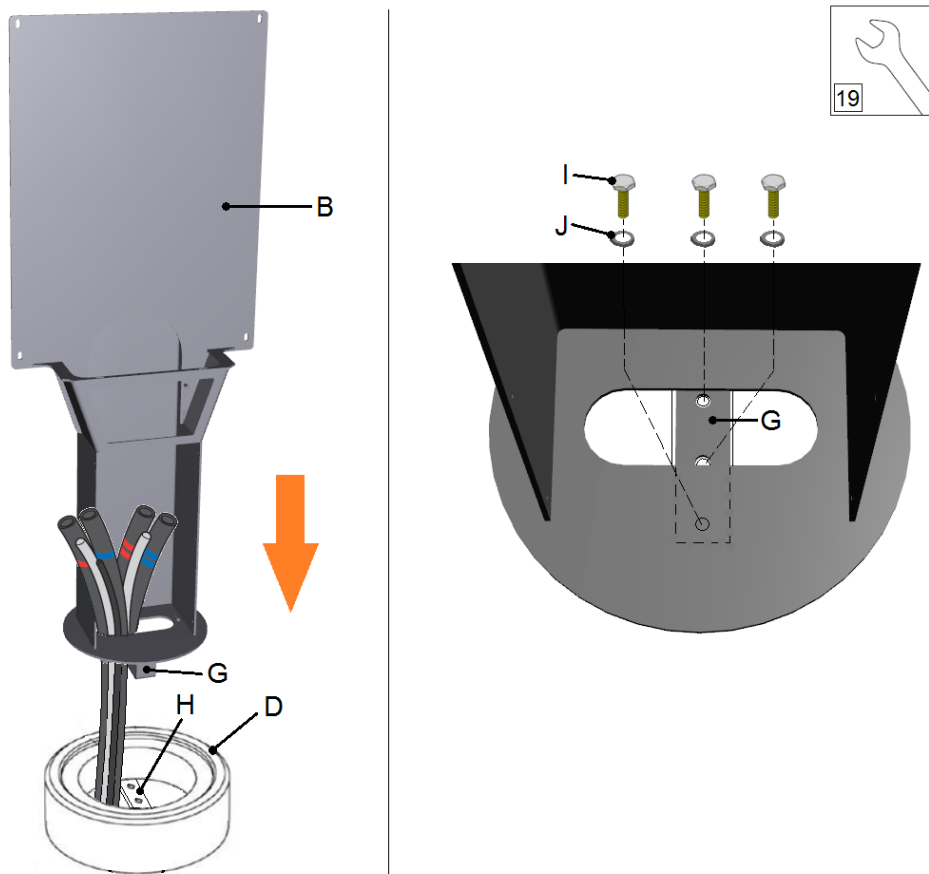

- Erect the Pedestal (B).



	NOTICE
<p>This must be carried out by two persons, who tilt the pedestal at one side.</p>	

6. Make sure that the pedestal's bow (G) is aligned with the tapped holes in the beam (H).
7. Insert M12 x 3.54 Inch bolts (I) fitted with washers (J) into the holes (3x).
8. Tighten the bolts with a tightening torque of 13 ft-lb.

5.12.2. Mounting Depot Charge Box onto Pedestal

Preconditions:

- All packaging material is removed from the Pedestal.
- A minimum of two persons is required.
- Tools: torx screwdriver (size TT20), spanner (size 13).

	WARNING
	Make sure that personnel cannot be crushed or become trapped while moving the Depot Charge Box.
	CAUTION
	Warranty Damage due to moving the Depot Charge Box to its position is not covered by the warranty.
	CAUTION
	Do not use a compressor to clean the Depot Charge Box. Use a vacuum cleaner.

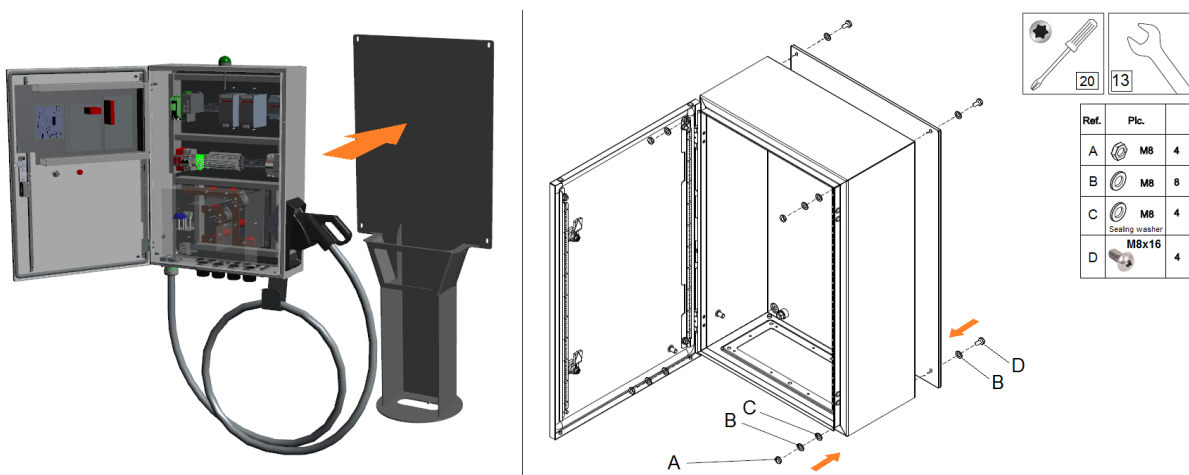



1. Open the door of the Depot Charge Box.
2. Carefully place the Depot Charge Box against the Pedestal.
3. Make sure that the Depot Charge Box is aligned with the holes in the metal plate of the Pedestal.
4. Insert the M8 bolts (D) and washers (B) into the holes at the back side of the Pedestal (4x).
5. Insert the M8 nuts (A), washer (B) and sealing washer (C) from the inside of the box onto the bolts (D) (4x).
6. Tighten the bolts/nuts with a tightening torque of 7 – 11 ft-lb.

5.13. Install Depot Charge Box onto wall

Preconditions:

- All packaging material is removed from the Depot Charge Box.
- A minimum of two persons is required.
- Tools: spanner (size 13).

	<p style="text-align: center;">WARNING</p> <p>Make sure that personnel cannot be crushed or become trapped while moving the Depot Charge Box.</p>
	<p style="text-align: center;">CAUTION</p> <p>Warranty Damage due to moving the Depot Charge Box to its position is not covered by the warranty.</p>
	<p style="text-align: center;">CAUTION</p> <p>Do not use a compressor to clean the Depot Charge Box. Use a vacuum cleaner.</p>

5.13.1. Using the wall-mounting brackets

The Depot Charge Box can be easily mounted by using the wall-mounting brackets, see *Wall-mounting brackets for safe wall fixing* on Page 20.

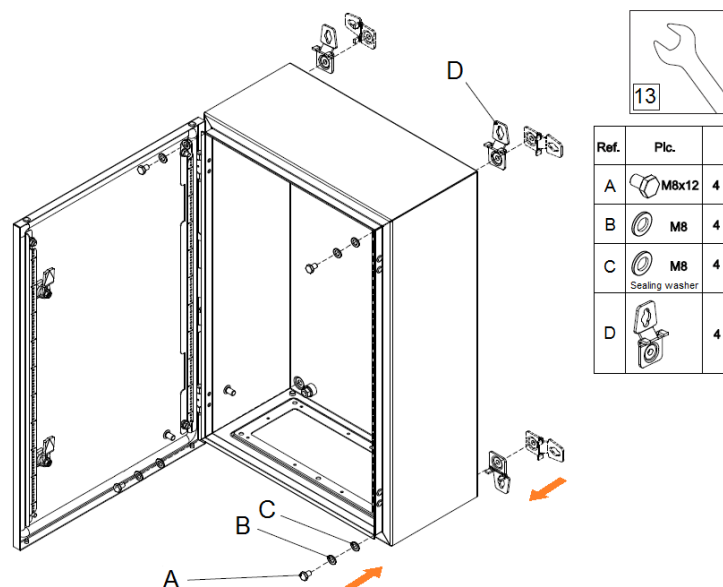

1. Determine whether the wall-mounting brackets (D) should be mounted horizontally or vertically, see also section *Workflow for wall mounting* on Page 42.
2. Open the door of the Depot Charge Box.
3. Put the wall-mounting brackets (D) (4x) against the back side of the Depot Charge Box.

4. Insert the M8 bolt (A), washer (B) and sealing washer (C) from the inside of the box into the holes of the back side into the wall-mounting brackets (D) (4x).
5. Tighten the bolts with a tightening torque of 7 – 11 ft-lb.
6. Close the door of the Depot Charge Box.

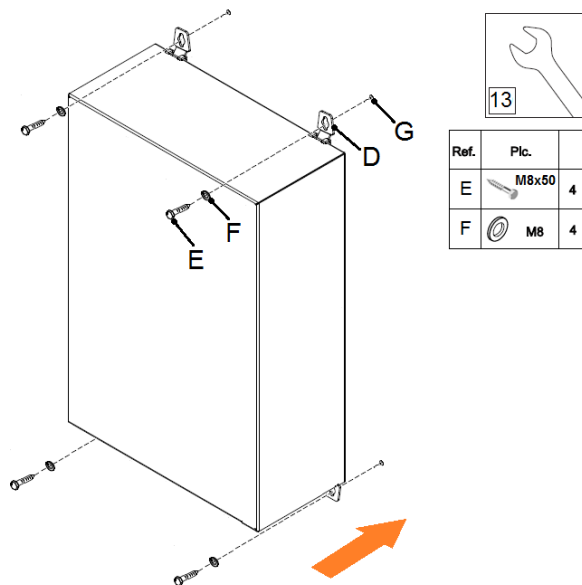

7. Carefully place the Depot Charge Box against the wall.
8. Make sure that the Depot Charge Box is aligned with the drilled holes (G) in the wall.
9. Insert the M8 wood-wire-bolts (E) fitted with the washers (F) into the holes of the wall-mounting brackets (D) (4x).
10. Tighten the wood-wire-bolts with a tightening torque of 7 – 11 ft-lb.

5.13.2. Direct wall mounting

1. Open the door of the Depot Charge Box.

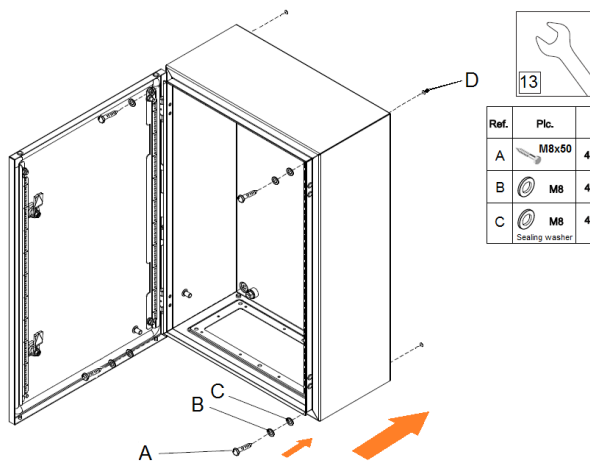

2. Carefully place the Depot Charge Box against the wall.
3. Make sure that the Depot Charge Box is aligned with the drilled holes (D) in the wall.
4. Insert the M8 wood-wire-bolts (A) fitted with the washers (B) and sealing washers (C) into the holes (4x).
5. Tighten the wood-wire-bolts with a tightening torque of 7 – 11 ft-lb.
6. Close the door of the Depot Charge Box.

5.14. Connect cables Depot Charge Box

	DANGER
	<p>Make sure that the main switch of the power supply group for the product is set to the OFF position. Do a voltage check to make sure that the electrical power is disconnected from the system. Secure against resetting.</p>

5.14.1. Gland layout of the Depot Charge Box

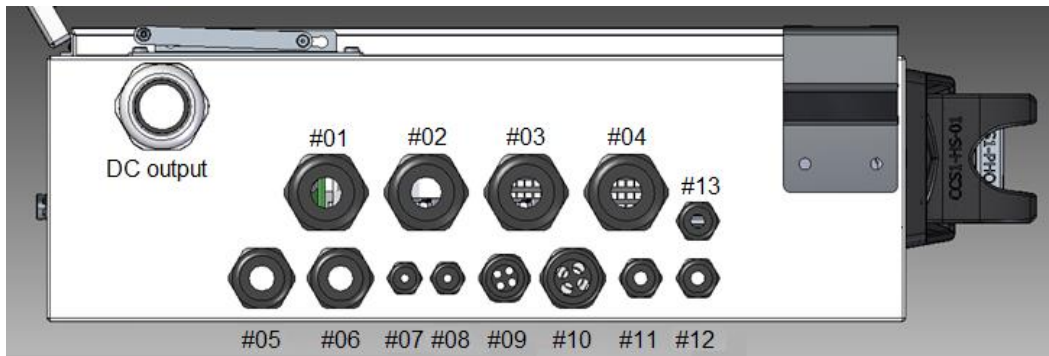

Gland #	Clamping range ØF	Cable
01	0.87 – 1.26 Inch	DC- Out
02	0.87 – 1.26 Inch	DC- In
03	0.87 – 1.26 Inch	DC+ In
04	0.87 – 1.26 Inch	DC+ Out
05	0.71 – 0.98 Inch	Communication In (fibers)
06	0.71 – 0.98 Inch	Communication Out (fibers)
07	0.20 – 0.39 Inch	Ethernet In
08	0.20 – 0.39 Inch	Ethernet Out
09	0.20 – 0.24 Inch	External EMO, Beacon, Stop button
10	0.32 – 0.35 Inch	Interlock In and Interlock Out
11	0.24 – 0.47 Inch	GND
12	0.24 – 0.47 Inch	AC auxiliary power Input
13	0.24 – 0.47 Inch	AC auxiliary power Output

5.14.2. Open the door of the Depot Charge Box

Preconditions

- Key that was removed from the Depot Charge Box.

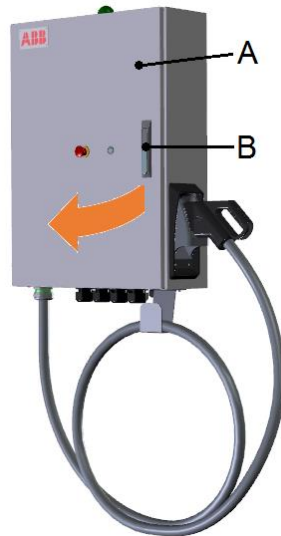

1. Unlock the handle (B).
2. Use the handle (B) to open the door (A).

5.14.3. Remove the protection cover

Preconditions:

- Tools: cross-head screwdriver

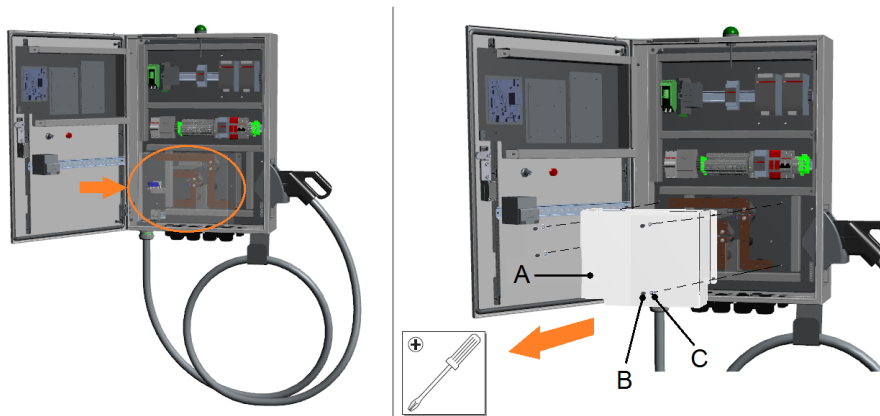

1. Remove the protection plate (A) by loosening the four screws (B).
2. Put the protection plate (A), the screws (B) and the washers (C) in a safe location as it will be installed again later on.

5.14.4. Connect the GND wire of the Power Cabinet

	WARNING
<p>In case the Pedestal is used, the GND wire from the Power Cabinet must first be connected to the GND point of the Pedestal. See section <i>Connect the GND or lighting protection wire onto Pedestal (when used)</i> on Page 85.</p>	

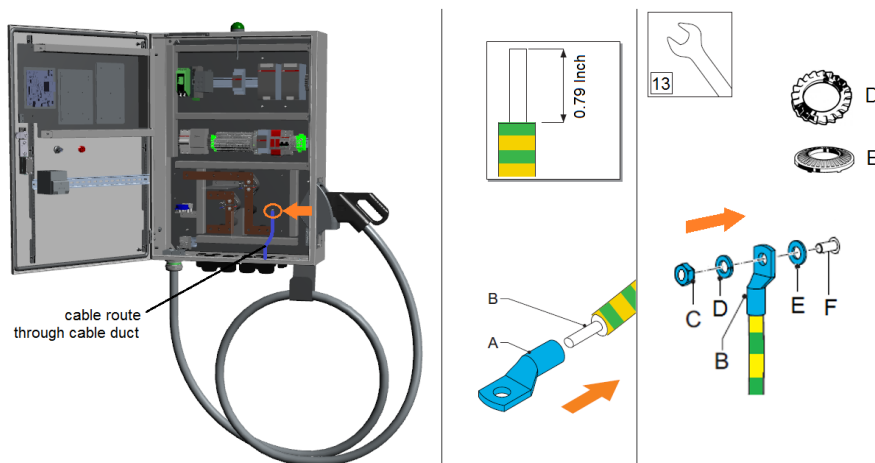

Preconditions:

- Tools: wire cutter, wire stripper pliers, ferrule, crimp pliers, screwdriver



- Loosen and remove the cable gland's (#11) nut for the GND wire.
- Slide the cable gland's nut over the GND wire.
- Route the GND wire (B) through gland #11 to the GND pin (F). Refer to the figure above for the preferred cable route through the cable duct inside the cabinet.
- Cut the GND wire to the correct length to reach the GND pin (F). Do not make the wire routing too tight, or too loose.
- Tighten the nut of the gland to secure the GND wire.
- Strip 0.79 Inch of the insulation from the end of the GND wire (B).
- Attach a wire end ring (A) to the end of the GND wire (B).
- Remove the M8 nut and washers from the GND pin (F).
- Insert the nut (C) with toothed washer (D), the GND wire (B) and the contact washer (E) onto the GND pin (F)
- Tighten the nut with a tightening torque of 11 ft-lb.

5.14.5. Install lighting protection (optional)

	NOTICE
	WARNING

When using this option, the GND wire between the Power Cabinet and the Depot Charge Box(es) don't have to be installed. See for more details section *Grounding of Depot Charge Boxes* on Page 46.

In case the Pedestal is used, the lighting protection wire must first connected to the GND point of the Pedestal. See section *Connect the GND or lighting protection wire onto Pedestal (when used)* on Page 85.

Preconditions:

- Tools: wire cutter, wire stripper pliers, ferrule, crimp pliers, screwdriver

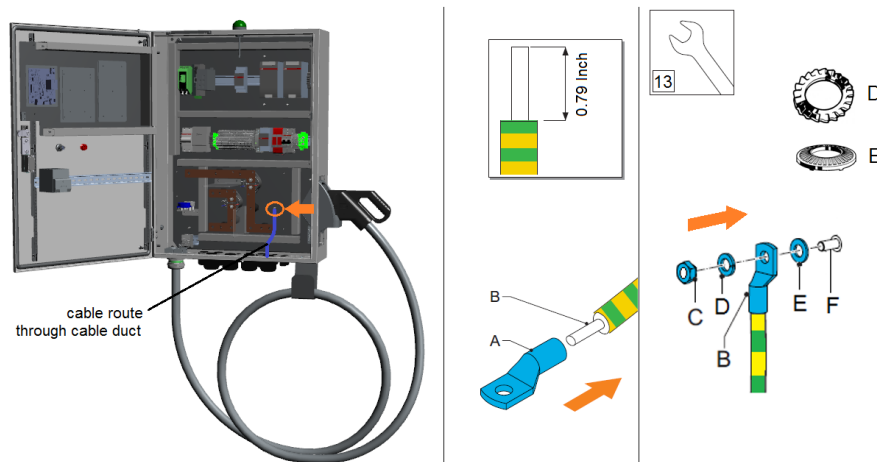

- Loosen and remove the cable gland's (#11) nut for the GND wire.
- Slide the cable gland's nut over the GND wire.
- Route the GND wire (B) through gland #11 to the GND pin (F). Refer to the figure above for the preferred cable route through the cable duct inside the cabinet.
- Cut the GND wire to the correct length to reach the GND pin (F). Do not make the wire routing too tight, or too loose.
- Tighten the nut of the gland to secure the GND wire.
- Strip 0.79 Inch of the insulation from the end of the GND wire (B).
- Attach a wire end ring (A) to the end of the GND wire (B).
- Remove the M8 nut and washers from the GND pin (F).
- Insert the nut (C) with toothed washer (D), the GND wire (B) and the contact washer (E) onto the GND pin (F)
- Tighten the nut with a tightening torque of 11 ft-lb.

5.14.6. Connect the GND or lighting protection wire onto Pedestal (when used)

Preconditions:

- Tools: wire cutter, wire stripper pliers, cable lugs (2x), spanner (size 13), torque wrench (size 13).

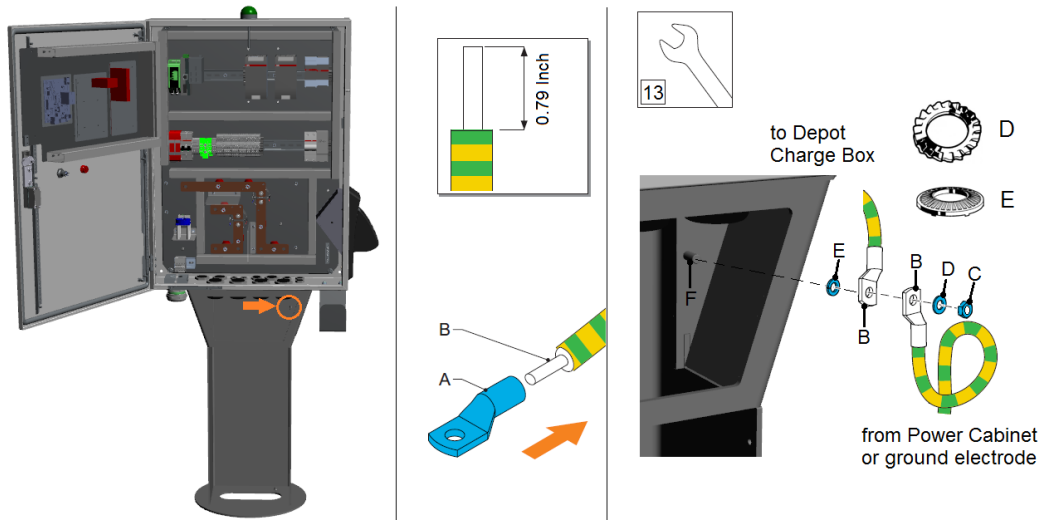

1. Make a loop in the GND wire that is coming from the Power Cabinet or ground electrode.

NOTICE	
	<p>For safety, it is recommended to make a loop in the GND wire. This loop makes sure that the GND wire is not the first wire that is disconnected if the Pedestal is moved by a collision.</p>

2. Cut the GND wire from the Power Cabinet or ground electrode to the correct length to reach the GND point (F).
3. Route the GND wire from the GND point (F) to the X1 terminal block within the Depot Charge Box. See also section *Connect the GND wire of the Power Cabinet* on Page 84 or *Install lighting protection (optional)* on Page 85. Do not make the wire routing too tight, or too loose.
4. Cut the GND wire to the Depot Charge Box to the correct length to reach the GND point (F).
5. Strip 0.79 Inch of the insulation from the end of the GND wires.
6. Attach a wire end ring (A) to the end of the GND wires (B).
7. Fit onto the GND point (F) the contact washer (E), both GND wires (B) and the toothed washer (D).
8. Screw onto the GND point (F) the M8 nut (D).
9. Tighten the nut with a tightening torque of 11 ft-lb.

5.14.7. Connect the DC power in- and output cables

Preconditions:

- Tools: wire cutter, wire stripper pliers, cable lugs, spanner (size 18), torque wrench (size 18).

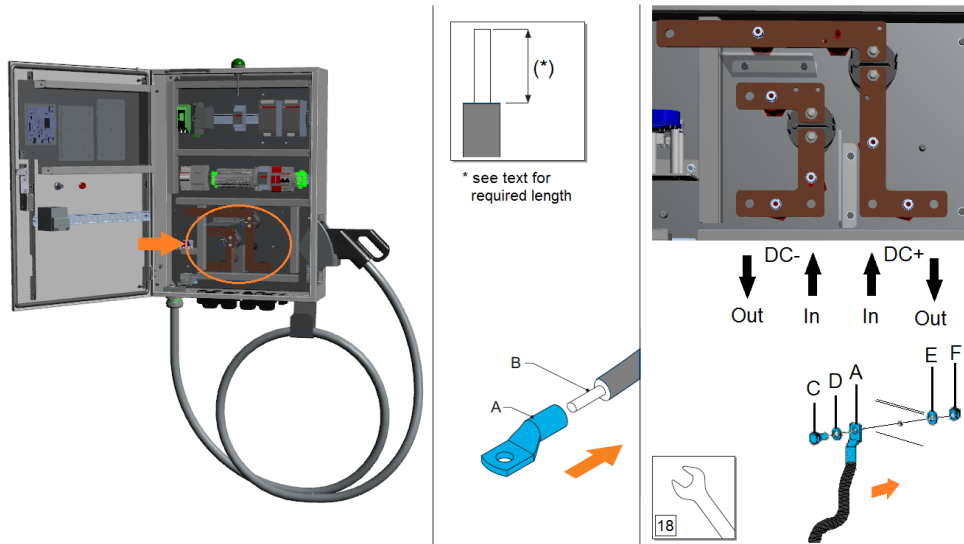

- Loosen and remove the cable gland's (#02 and #03) nuts for the DC power input cables. In case of sequential charging with two or three Depot Charge boxes, loosen and remove also the cable gland's (#01 and #04) nuts for the DC power output cables.
- Slide the cable gland's nuts over the DC power cables.
- Strip the insulation on the required length specified by the used lug from the end of the wire (B).
- Insert the DC power cables into the cable gland (#01 - #04).
- Attach cable lug (A) at the end of the wires.
- Fit a M12 bolt (C) with washer (D) and the DC cable (A).
- Insert the bolt fitted with the DC cable into the right connection hole of the copper rail (see picture above).
- Screw from the bottom side of the copper rail a washer (E) and a nut (F) on the bolt (C).
- Tighten the bolt/nut connection with a tightening torque of 15 ft-lb.
- Tighten the cable gland's nut to secure the DC power cables.

5.14.8. Connect the AC auxiliary power cable(s)

Preconditions:

- Tools: wire cutter, wire stripper pliers, ferrule, crimp pliers, screwdriver

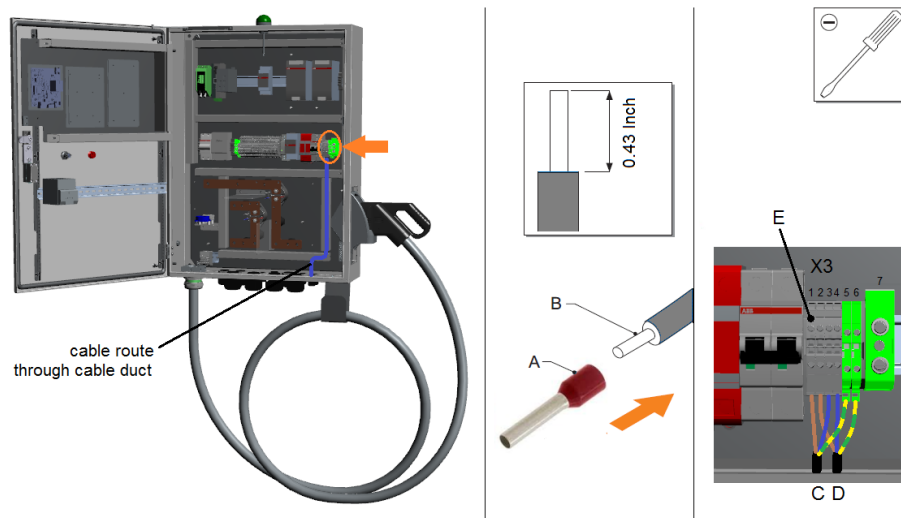

- Loosen and remove the cable gland's (#12) nut for the AC auxiliary power Input cable (C). In case of daisy-chained connection of the AC auxiliary supply (see section *Charge system configurations* on Page 43), loosen and remove also the cable gland's (#13) nut for the AC auxiliary power output cable (D).
- Slide the cable gland's nut over the AC auxiliary power cable.
- Route the AC auxiliary power cable(s) through gland #12 (and #13) to terminal block (E). Refer to the figure above for the preferred cable route through the cable duct inside the cabinet.
- Cut the AC auxiliary power cable to the correct length to reach the terminal block (E). Do not make the cable routing too tight, or too loose.
- Tighten the nut of the gland to secure the AC auxiliary power cable(s).
- Strip 0.43 Inch of the insulation from the end of the wires (B).
- Crimp a ferrule (A) to the end of the wire (B).
- Loosen the connector screws.
- Insert the wires of the AC auxiliary power cable(s) into the connectors of the terminal block (E):

Functional description	Connector	Wire color
AC aux Line Input	X3-1	Brown
AC aux Line Output (to next Depot Charge Box, optional)	X3-2	Brown
AC aux Neutral Input	X3-3	Blue
AC aux Neutral Output (to next Depot Charge Box, optional)	X3-4	Blue
AC aux GND Input	X3-5	Green/yellow
AC aux GND Output (to next Depot Charge Box, optional)	X3-6	Green/yellow

- Tighten the connector screw of the terminal blocks with a tightening torque of 1 ft-lb.

5.14.9. Connect the Interlock cable(s)

Preconditions:

- Tools: wire cutter, wire stripper pliers, screwdriver, ferrules, crimp pliers

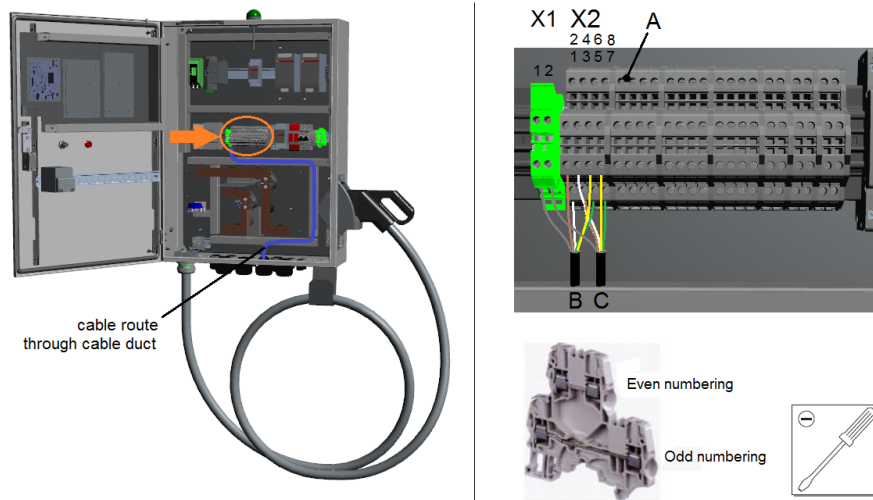

- Loosen and remove the cable gland's (#10) nut for the Interlock cables (B) and (C). In case of sequential charging with two or three Depot Charge boxes, Interlock cable (C) is used for the Interlock connection between the Depot Charge Boxes.
- Slide the cable gland's nut over the Interlock cable(s).
- Route the Interlock cable(s) through gland #10 to the terminal blocks (A). Refer to the figure above for the preferred cable route through the cable duct inside the cabinet.
- Cut the Interlock cable(s) to the correct length to reach the terminal block (A). Do not make the cable routing too tight, or too loose.
- Tighten the nut of the gland to secure the Interlock cable(s).
- Strip 0.43 Inch of the insulation from the end of the wires.
- Tighten the shield of the Interlock cable(s) into a thread and slide a shrink tubing over the shield that has been twisted together.
- Crimp a ferrule to the end of the wires.
- Loosen the connector screws.
- Connector between pin X2-3 and X2-4 must not be present if the Interlock cable (C) is routed to the next Depot Charge Box. Connector between pin X2-3 and X2-4 must be present if this is the last Depot Charge Box.
- Insert the wires of the Interlock cable(s) into the connectors of the terminal block (A):

Functional description	Connector	Wire color
Interlock In (from Power Cabinet or previous Depot Charge Box, optional)	X2-1	White
Interlock Out (from Power Cabinet or previous Depot Charge Box, optional)	X2-2	Brown
DC Guard A (from Power Cabinet or previous Depot Charge Box, optional)	X2-5	Green
DC Guard A GND (from Power Cabinet or previous Depot Charge Box, optional)	X2-6	Yellow
Interlock GND	X1-1	Shield
Interlock In (to next Depot Charge Box, optional)	X2-3	Brown
Interlock Out (to next Depot Charge Box, optional)	X2-4	White
DC Guard A (to next Depot Charge Box, optional)	X2-7	Green
DC Guard A GND (to next Depot Charge Box, optional)	X2-8	Yellow
Interlock GND	X1-2	Shield

See also Appendix F *Signal connection diagram*.

12. Tighten the connector screw of the terminal blocks with a tightening torque of 1 ft-lb.

5.14.10. Connect the communication glass fiber cable(s)

1. Loosen and remove the cable gland's (#05) nut for the communication (CAN/Ethernet) glass fiber cable. In case of sequential charging with two or three Depot Charge boxes, also loosen and remove the cable gland's (#06) nut for the communication (CAN) glass fiber cable.
2. Slide the cable gland's nut (A) over the metal finish tulle of the communication glass fiber cable(s).
3. Insert the communication cable into the cable gland (#05 and #06) and tighten the cable gland's nut to secure the cable(s).

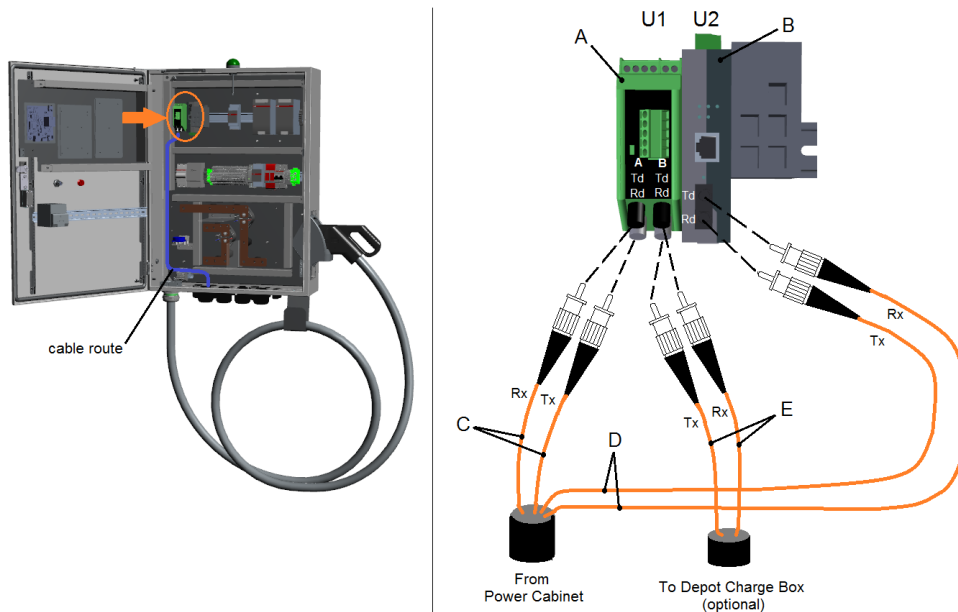

4. Route the communication fiber cables to module U1 (A) and U2 (B). Refer to the figure above for the preferred cable route inside the cabinet.
5. Remove the protection covers from the optical connectors.
6. Connect the two CAN bus fiber cables (C) onto module (A):
 - Rx (Optical 1) with A-Td U1;
 - Tx (Optical 2) with A-Rd U1.
7. Connect the two Ethernet fiber cables (D) onto module (B):
 - Rx (Optical 1) with Td U2;
 - Tx (Optical 2) with Rd U2.
8. In case of sequential charging, connect the two CAN bus fiber cables (E) onto module (A):
 - Rx (Optical 1) with B-Td U1;
 - Tx (Optical 2) with B-Rd U1.



NOTICE

From the CAN/Ethernet glass fiber cable, four fiber cables are not connected and from the CAN glass fiber cable, two fiber cables are not connected. Those fiber cables are meant for spare.

9. Bind the cables together and secure the loops loosely with a piece of tak-ty or ty-rap.

	CAUTION
	<p>Make the loop bend radius of the fiber cables not smaller than 2.52 Inch, otherwise the core of the fiber cable may break.</p>

5.14.11. Connect the Ethernet cable between the Depot Charge Boxes

	NOTICE
	<p>The Ethernet cable connection between the Depot Charge Boxes is only needed in case of sequential charging with two or three Depot Charge boxes, see for more details section <i>Cabling</i> on Page 43.</p>

Preconditions:

- Tools: network cable pliers, 2x or 4x RJ45 connectors.

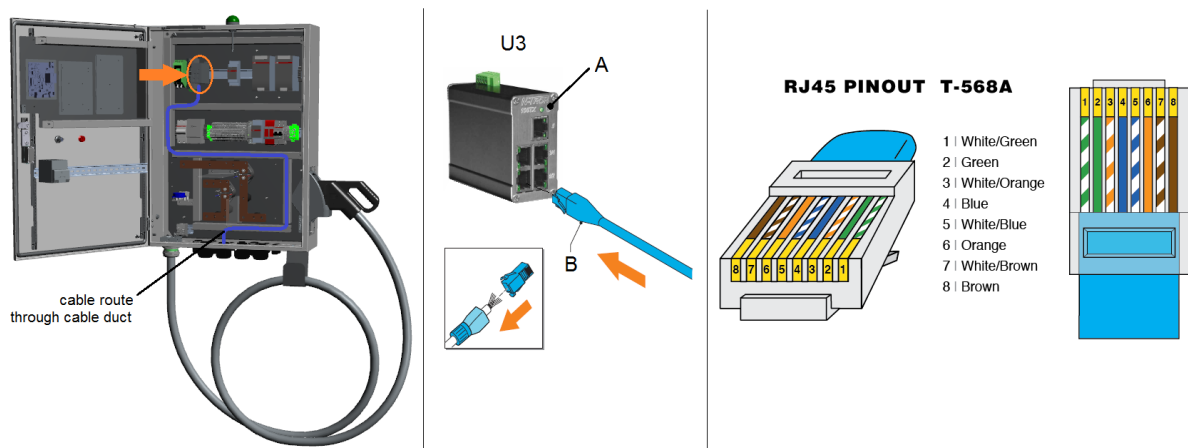

- Loosen and remove the cable gland's (#07 and #08, only in case of three Depot Charge boxes configuration) nut for the Ethernet cable(s).
- Slide the cable gland's nut over the Ethernet cable(s).
- Route the Ethernet cable(s) through gland #7 (and #08) to the module (A). Refer to the figure above for the preferred cable route through the cable duct inside the cabinet.
- Cut the Ethernet cable(s) to the correct length to reach the module (A). Do not make the cable routing too tight, or too loose.
- Tighten the nut of the gland to secure the Ethernet cable(s).
- Fit an RJ45 connector to the Ethernet cable (B). Use network cable pliers.
- Insert the RJ45 connector into the network terminals X3 or X4 of module U3 (A).

5.14.12. Connect external EMO, Beacon and Stop button cables (optional)

	NOTICE
<p>There is the possibility to connect an external Beacon light, Stop button and/or Emergency stop button (EMO) to the Depot Charge Box, see for more details section <i>Optional external interface cables</i> on Page 47.</p>	

Preconditions:

- Tools: wire cutter, wire stripper pliers, screwdriver, ferrules, crimp pliers

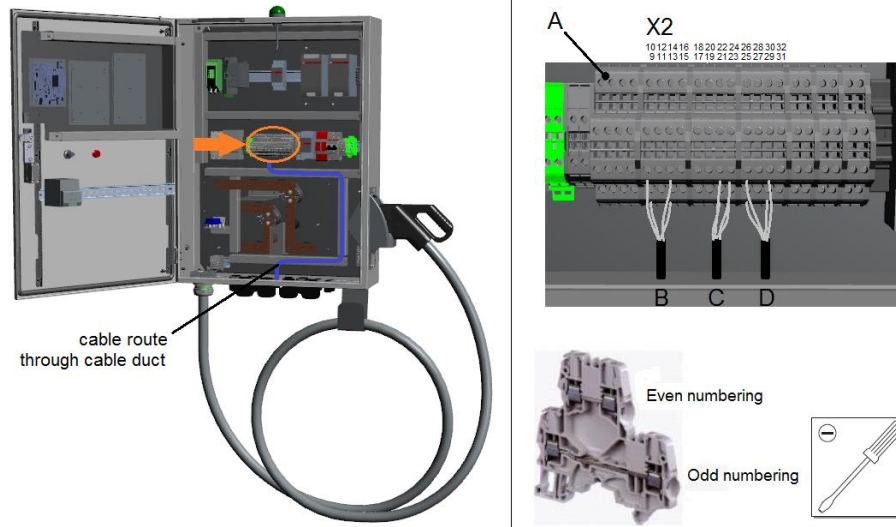

- Loosen and remove the cable gland's (#9) nut for the Ext. Beacon cable (B), the Ext. Stop button cable (C) and the Ext. EMO cable (D).
- Slide the cable gland's nut over the cables.
- Route the cables through gland #9 to the terminal blocks (A). Refer to the figure above for the preferred cable route through the cable duct inside the cabinet.
- Cut the cables to the correct length to reach the terminal block (A). Do not make the cable routing too tight, or too loose.
- Tighten the nut of the gland to secure the cables.
- Strip 0.43 Inch of the insulation from the end of the wires.
- Crimp a ferrule to the end of the wires.
- Loosen the connector screws.
- Connectors between pin X2-21 and X2-22 and between pin X2-23 and X2-24 must be removed if the Ext. EMO button is applied.

10. Insert the wires of the cables into the connectors of the terminal block (A):

Functional description	Connector
External stop button +	X2-9
External stop button -	X2-10
External stop button +24 V	X2-13
External stop button 0 V	X2-14
External emergency button S1-1	X2-21
External emergency button S1-2	X2-22
External emergency button S2-1	X2-23
External emergency button S2-2	X2-24
External beacon light Red	X2-25
External beacon light Green	X2-26
External beacon light Blue	X2-29
External beacon light +24 V	X2-30

See also Appendix F *Signal connection diagram*.

11. Tighten the connector screw of the terminal blocks with a tightening torque of 1 ft-lb.

5.14.13. Install the protection cover

Preconditions:

- Tools: cross-head screwdriver

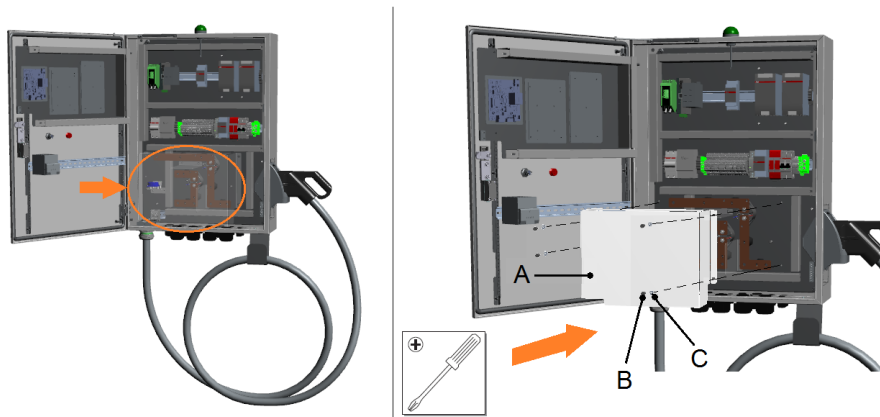

1. Take the protection cover, the screws and the washers that was removed in *Remove the protection cover* on Page 83.
2. Place the protection cover (A) back over the DC contactors and secure the protection cover by the screws (B) in combination with the washers (C).

5.14.14. Close the door of the Depot Charge Box

Preconditions

- Key that was removed from the Depot Charge Box

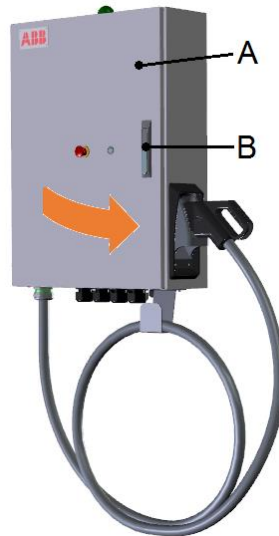

1. Close the door (A).
2. Lock the handle (B).

5.14.15. Install front cover plate on Pedestal (when used)

Preconditions:

- Tools: torx screwdriver (size TT20).

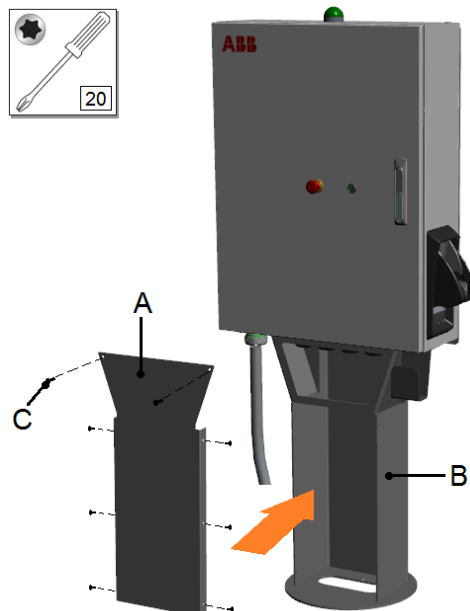

1. Put the front cover plate (A) against the front side of the Pedestal (B).
2. Insert the M8 bolts (C) into the holes (8x).
3. Tighten the bolts.

6. Commissioning

6.1. Commissioning preparation

Commissioning is the last phase necessary to get the HVC-C 100/150 E-Bus Charger into operation.

The planning steps for the commissioning phase are shown in the figure below.

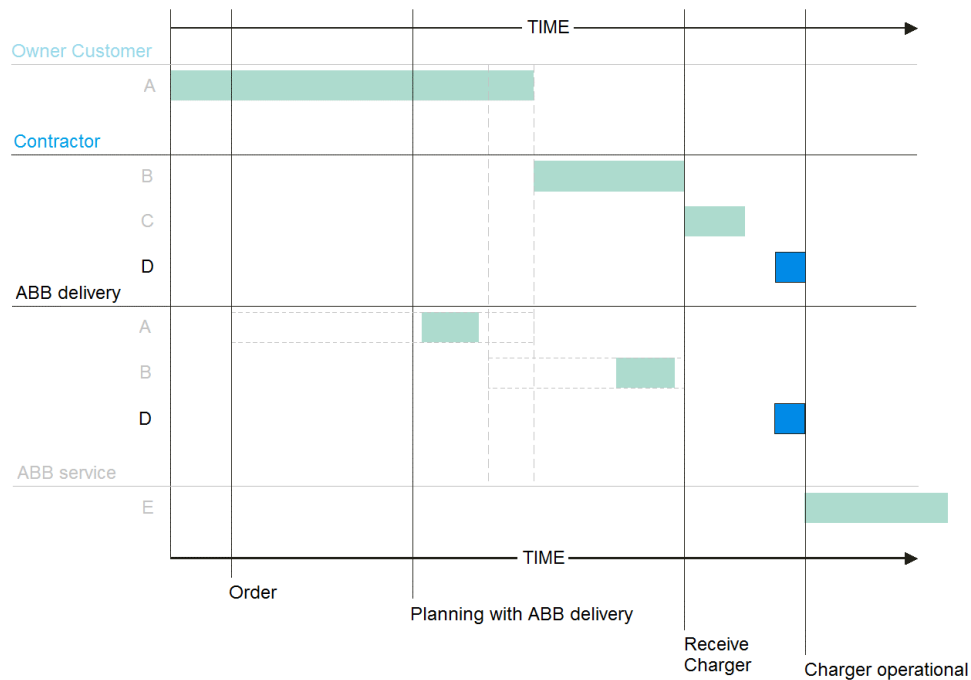

D Commissioning

The commissioning of the HVC-C 100/150 E-Bus Charger need to be performed by a service engineer from the ABB Delivery department and/or a certified local ABB service engineer. Both will need the support from the local contractor.

Before the service engineer can start, the following conditions must be met:

- All installation work is done.
- Grid power is available.
- A local technician is present for assistance and to switch the power on.
- An electric or hybrid bus available to perform the functional tests.

CAUTION	
	<p>Warranty</p> <p>It is not permitted to move the whole or parts of the HVC-C 100/150 E-Bus Charger after the commissioning. If the whole or parts of the HVC-C 100/150 E-Bus Charger is moved without contacting the ABB Service department, the warranty will be considered void.</p>

6.2. Customer Acceptance Form (CAF)

After the commissioning is completed, the owner / site operator will sign the Customer Acceptance Form (CAF). In certain circumstances ABB will be represented by a project engineer.

The CAF contains information about:

- the project (number, location, charger type),
- a checklist about the delivery,
- the commissioning SAT checklist,
- list of remaining items.

After the CAF has been signed, the customer support will be handled by the ABB Service department.

If there are any remaining items, they can be noted on the CAF document, together with the agreed solution and the expected date of completion.

7. Service and Maintenance

7.1. About Service and Maintenance

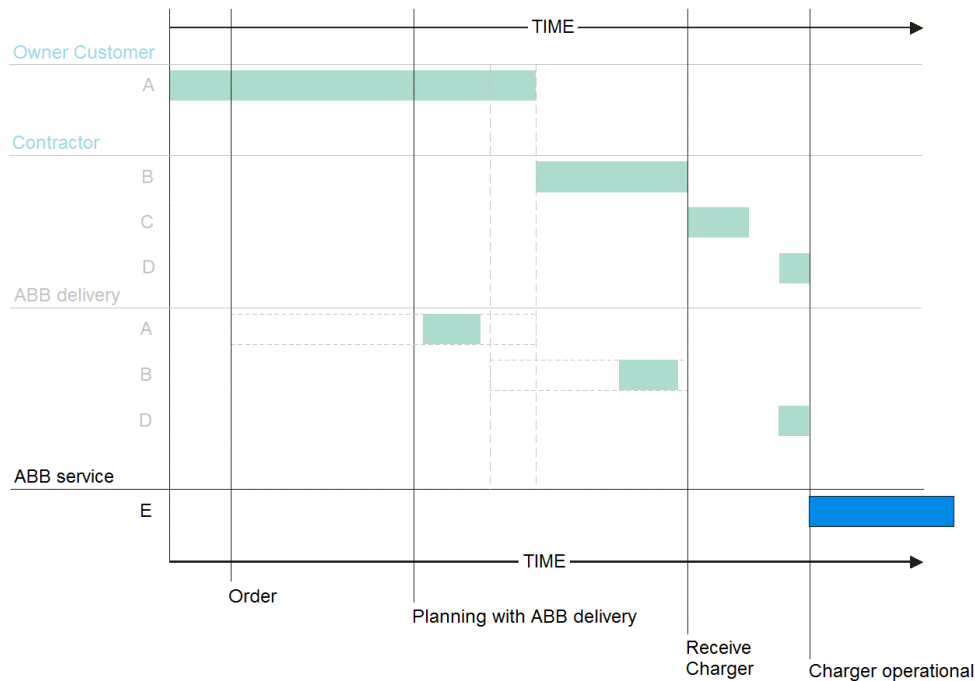



E Service and Maintenance

Maintenance is done according to the maintenance schedule. This is outside of the scope of this document.

7.2. Cleaning of the cabinet

The Power Cabinet and ABB Pole is powder coated. This coating must be kept in good condition. Clean the Power Cabinet and ABB Pole three times a year in the following way:

- Remove rough dirt by spraying with low-pressure tap water.
- Apply a neutral or weak alkaline cleaning solution and let it soak.
- Remove dirt by hand with a non-woven nylon hand pad.
- Rinse thoroughly with tap water.
- Optionally, apply wax on the front for extra protection and gloss.
- Do a check on the coating for damage.

	NOTICE
	<p>When the HVC-C 100/150 E-Bus Charger is exposed to rain, it is sufficient to clean it twice a year.</p>
	CAUTION
	<p>Do not apply high-pressure water jets. Water may leak into the Power Cabinet. If a high-pressure water jet has been used, make sure that the inside of the Power Cabinet is dry.</p> <ul style="list-style-type: none"> - Only use cleaning agents with a pH value between 6 and 8. - Do not use cleaning agents with abrasive components. - Do not use abrasive tools.

8. Technical Specification

8.1. Electrical specification complete 100 kW system

AC Input Power Cabinet	
Supply voltage	3-phase: GND, L1, L2, L3
Input voltage range	480/277 V AC \pm 10% 600/347 V AC +10%/-15% (Canada version)
Input frequency range	60 Hz \pm 1%
Maximum power dissipation	110 kVA
Power factor (cos φ)	\geq 0.95 (> 0.97 at full load)
Standby power consumption	< 60 W
Efficiency	94% and 96% in power spectrum between 20% and 100% of full power
Nominal input current	132 A AC 106 A AC (Canada version)
Earth Leakage Current protection	AC 300 mA (GFCI integrated in HVC100) AC 30 mA (GFCI integrated in ACS Control Module)
Short Circuit Capacity	25 kA
AC power connection	240 mm ² = 500 MCM (max)
AC Input Depot Charge Box	
Supply voltage	1-phase: GND, L, N
Input voltage range	90 - 132 V AC \pm 10%
Input frequency range	47 - 63 Hz \pm 1%
Nominal input current	2.2 A AC
Earth Leakage Current protection	AC 30 mA
DC output	
Maximum output power	100 kW
Output voltage range	150 – 850 V DC
Maximum output current	134 A DC

8.1. Electrical specification complete 150 kW system

Input	
Supply voltage	3-phase: GND, L1, L2, L3
Input voltage range	480/277 V AC \pm 10%
	600/347 V AC +10%/-15% (Canada version)
Input frequency range	60 Hz \pm 1%
Maximum power dissipation	170 kVA
Power factor (cos φ)	\geq 0.95 (> 0.97 at full load)
Standby power consumption	< 60 W
Efficiency	94% and 96% in power spectrum between 20% and 100% of full power
Nominal input current	198 A AC
	163 A AC (Canada version)
Earth Leakage Current protection	AC 300 mA (GFCI integrated in HVC150(S)) AC 30 mA (GFCI integrated in ACS Control Module)
Short Circuit Capacity	25 kA
AC power connection	240 mm ² = 500 MCM (max)
AC Input Depot Charge Box	
Supply voltage	1-phase: GND, L, N
Input voltage range	90 - 132 V AC \pm 10%
Input frequency range	47 - 63 Hz \pm 1%
Nominal input current	2.2 A AC
Earth Leakage Current protection	AC 30 mA
DC output	
Maximum output power	150 kW
Output voltage range	150 – 850 V DC
Maximum output current	200 A DC

8.2. Mechanical data

Mechanical specification Power Cabinet

Dimensions (H x W x D)	82.36 x 46.06 x 30.32 Inch (Including swivel eye bolts)
Weight	2954.19 lb
Volume	114114.40 in ³
Dimensions including packaging (H x W x D)	88.58 x 47.24 x 31.50 Inch
Weight including packing	3086.47 lb
Weight concrete foundation	2866.00 lb
Mechanical impact protection	IK10
Housing	Stainless steel 430

Mechanical specification Depot Charge Box

Dimensions (H x W x D)	6.65 x 27.52 x 9.45 Inch (exclusive charge cable)
Weight	99.21 lb (exclusive with charge cable) 116.85 lb (with 3.5 m charge cable) 134.48 lb (with 7.0 m charge cable)
Volume	6102.37 in ³
Dimensions including packaging (H x W x D)	49.21 x 35.43 x 20.87 Inch (including pallet)
Weight including packing	224.87 lb
Mechanical impact protection	IK10
Housing	Stainless steel 304

8.3. Environment

Environment specification Power Cabinet

Ingression protection	IP54
Temperature range – Operation	-35 °C to +45 °C
Temperature range – Storage	-10 °C to +70 °C
Humidity	5 % to 95 %, RH – non-condensing
Airflow	51206.27 ft ³ /h
Pressure drop	300 pA
Altitude	6561.68 ft (max.)
Storage conditions	Indoors, dry

Environment specification Depot Charge Box

Ingression protection	IP65 (exclusive charge cable)
Temperature range – Operation	-35 °C to +45 °C
Temperature range – Storage	-10 °C to +70 °C
Humidity	5 % to 95 %, RH – non-condensing
Altitude	6561.68 ft (max.)
Storage conditions	Indoors, dry

	CAUTION
	<p>Warranty Warranty will be considered void when the HVC-C 100/150 E-Bus Charger is damaged while badly stored at the customer's location.</p>

8.4. Certifications

Certifications for complete system

UL 2202	HVC 150: Certificate No. TU 72180445
Class of protection	1 with GND connection

9. Appendix

A	Dimensions Power Cabinet	102
B	Dimensions Depot Charge Box	104
C	Dimensions Concrete Foundation	105
D	Dimensions Metal Foundation	107
E	Power Cabinet – Outline with Foundation	108
F	Signal connection diagram	109
G	Ground overview of the system	110

A. Dimensions Power Cabinet

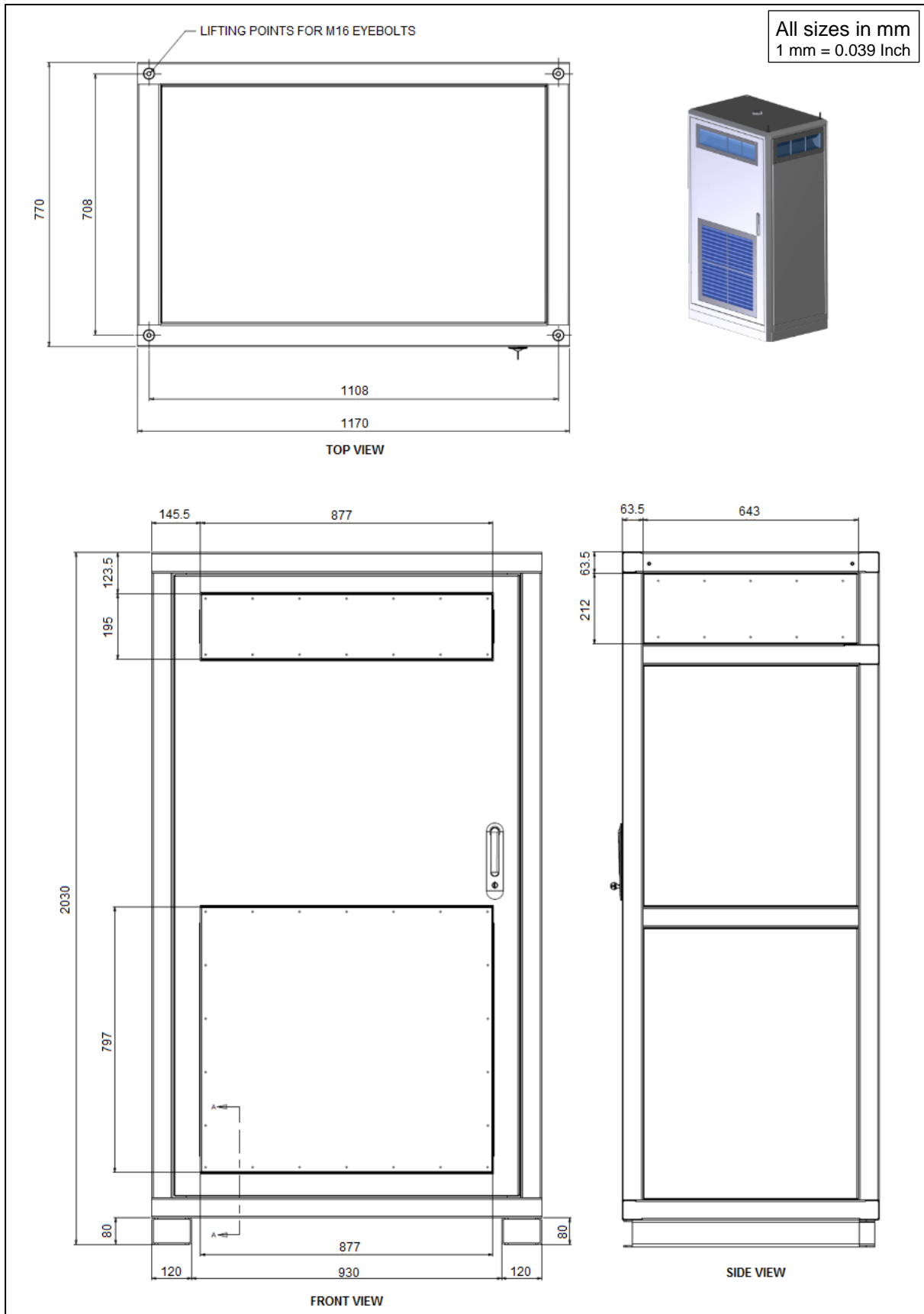

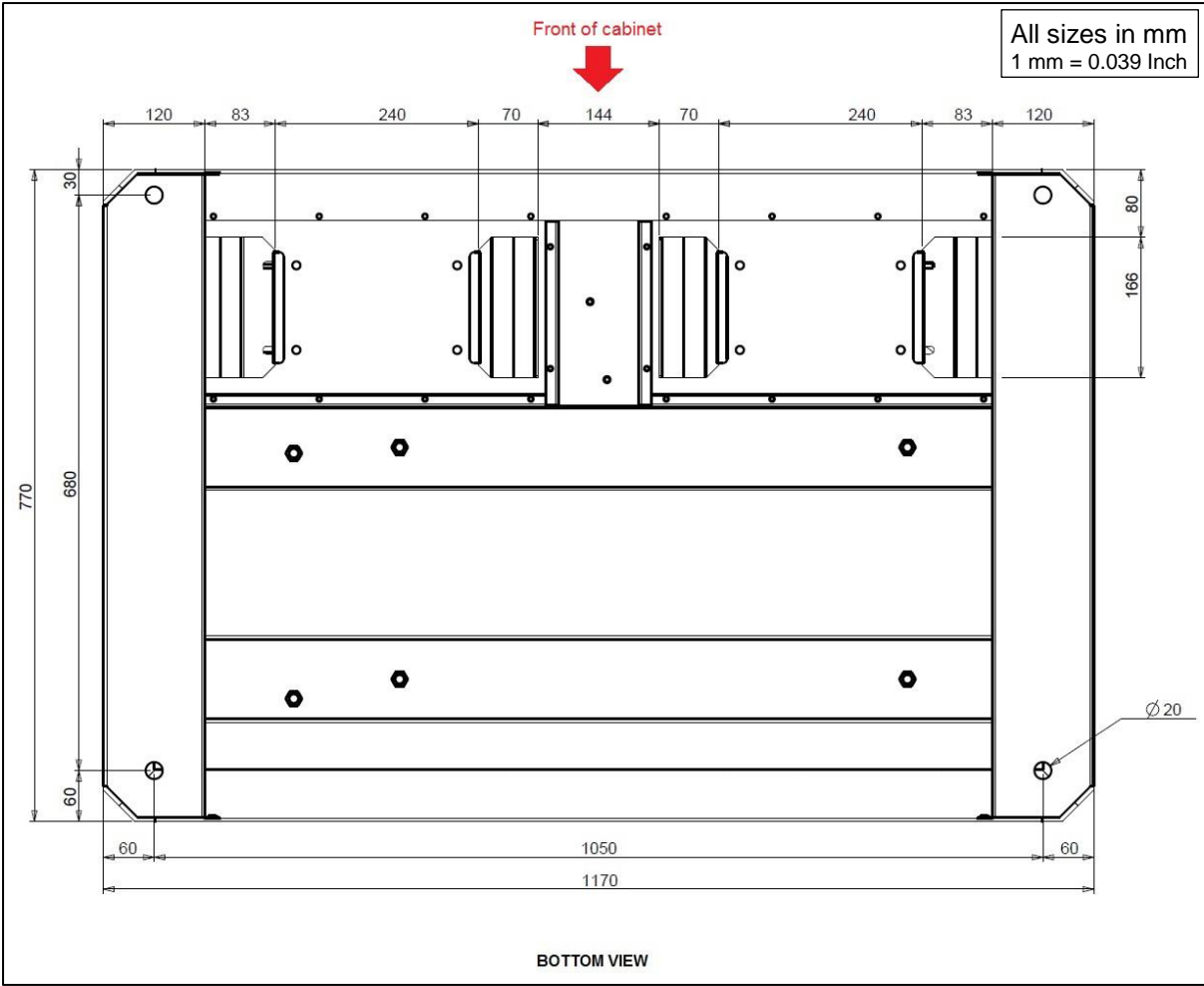

B. Dimensions Depot Charge Box

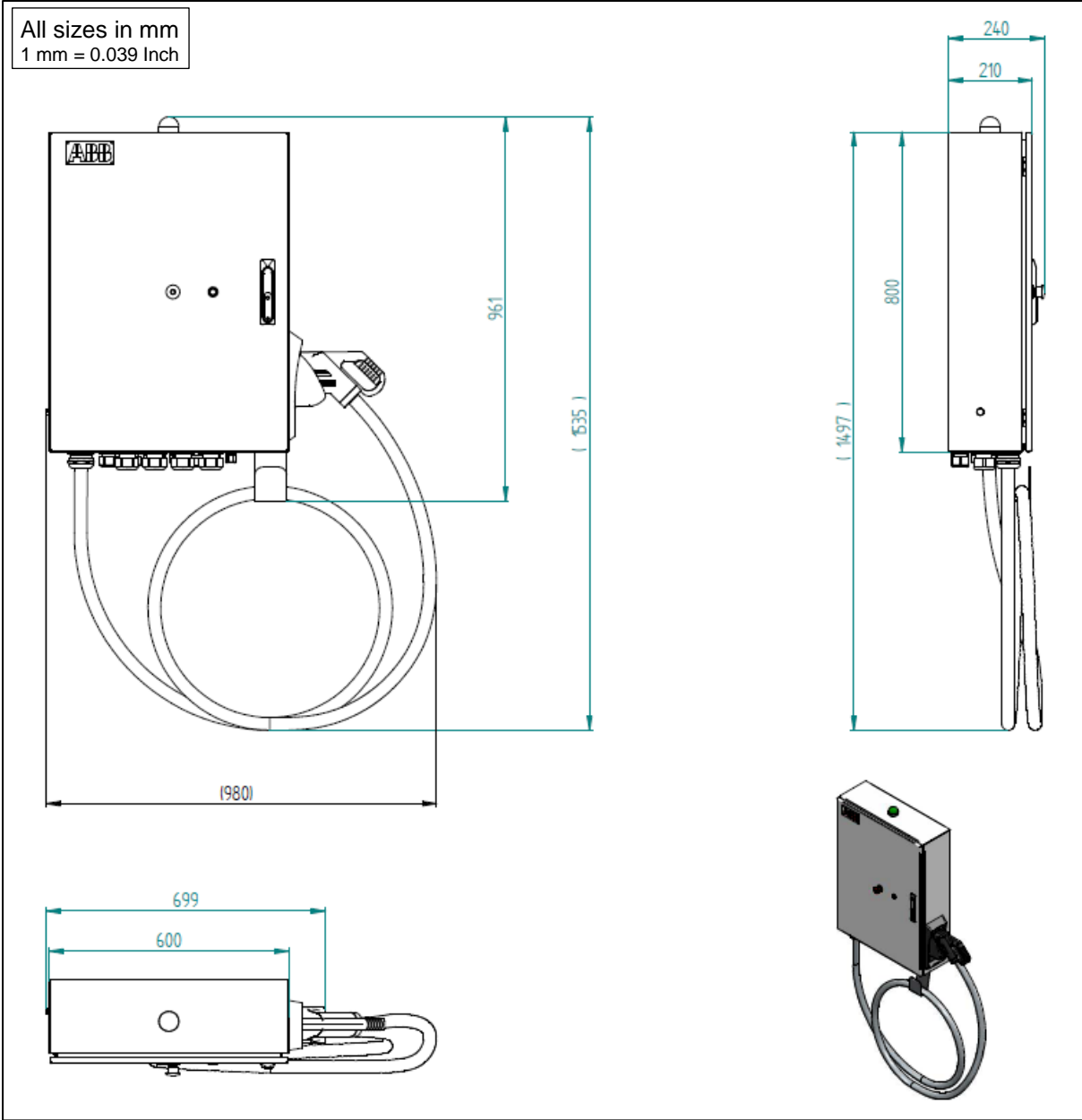

C. Dimensions Concrete Foundation Power Cabinet

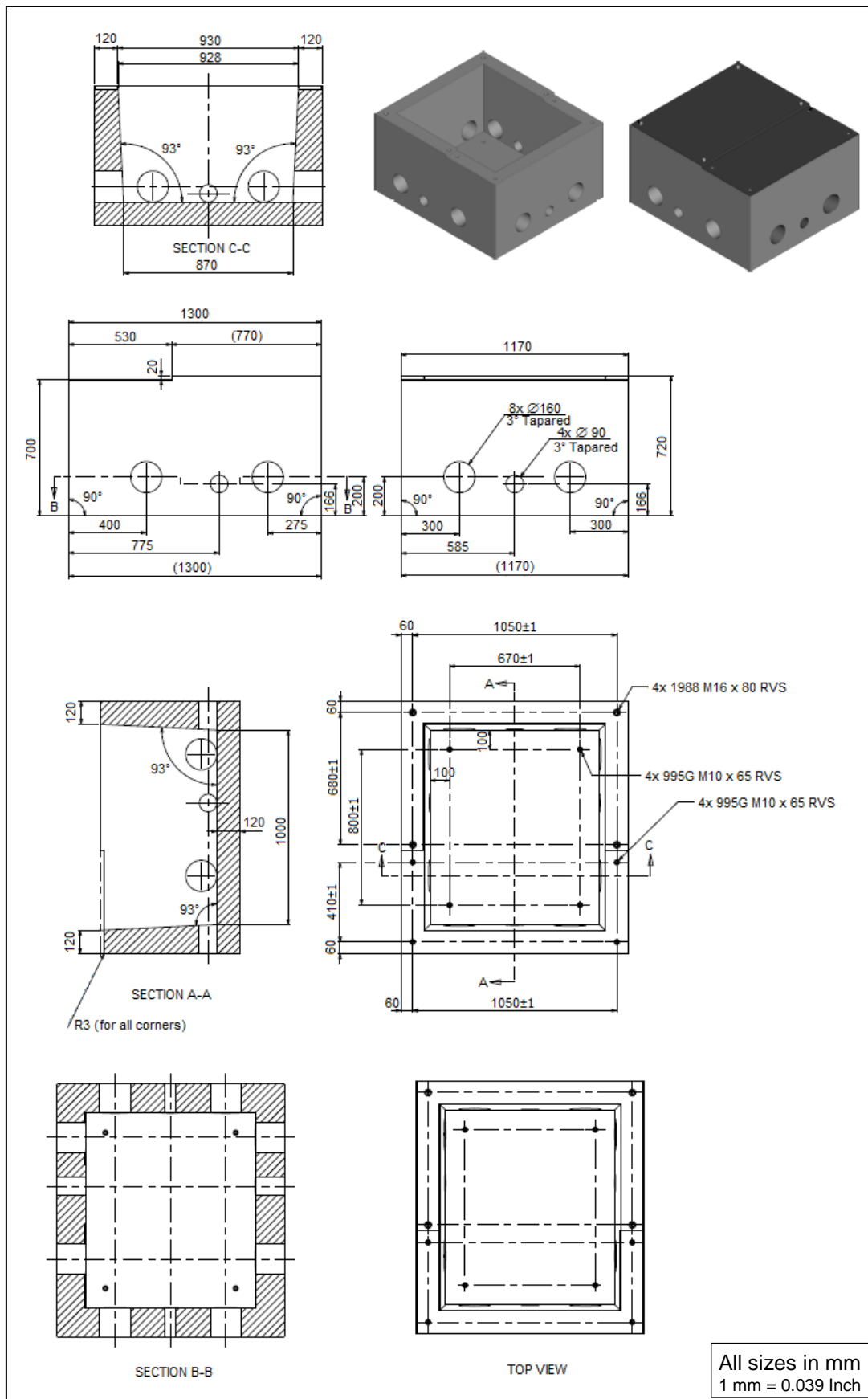

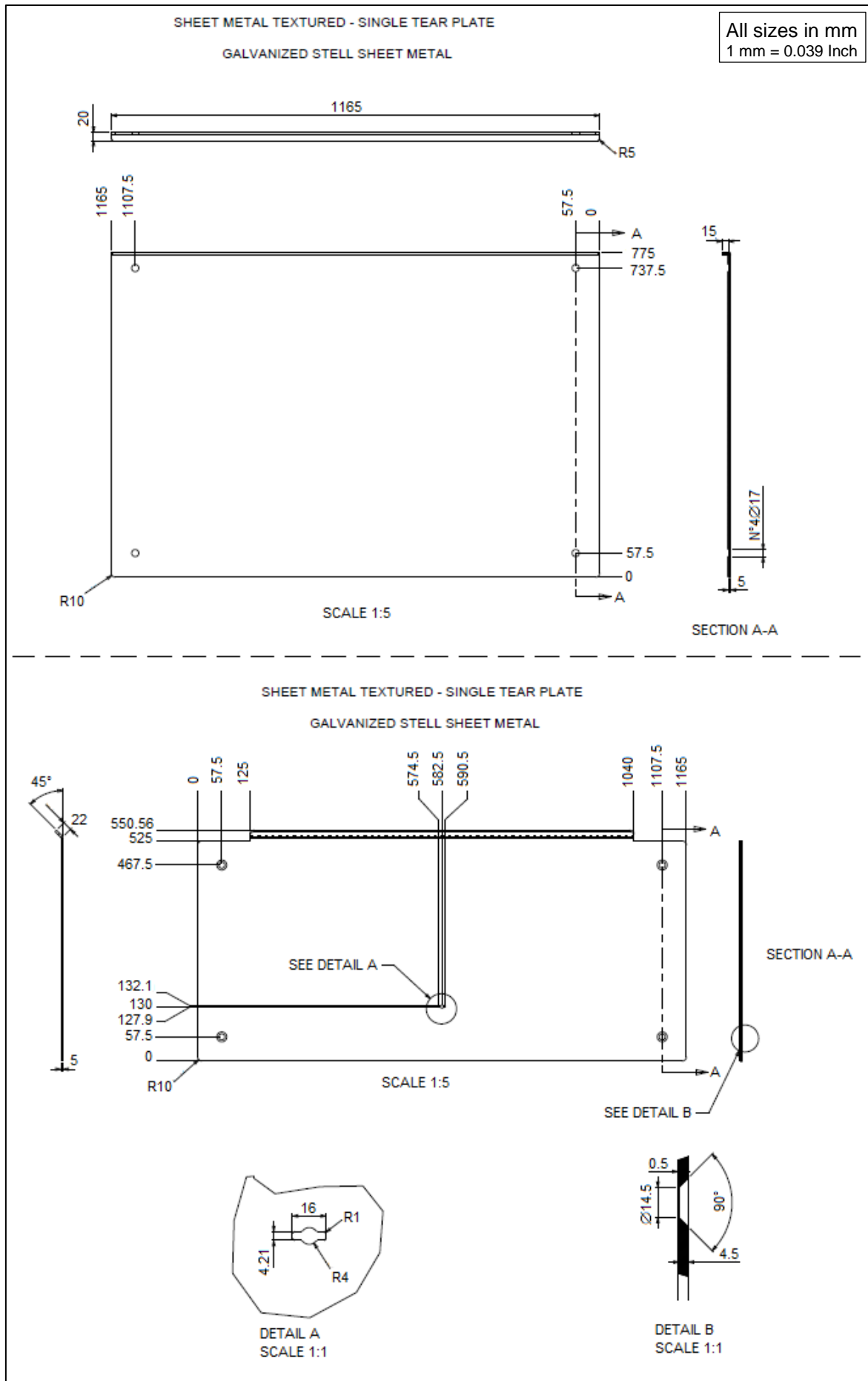

D. Dimensions Metal Foundation Power Cabinet

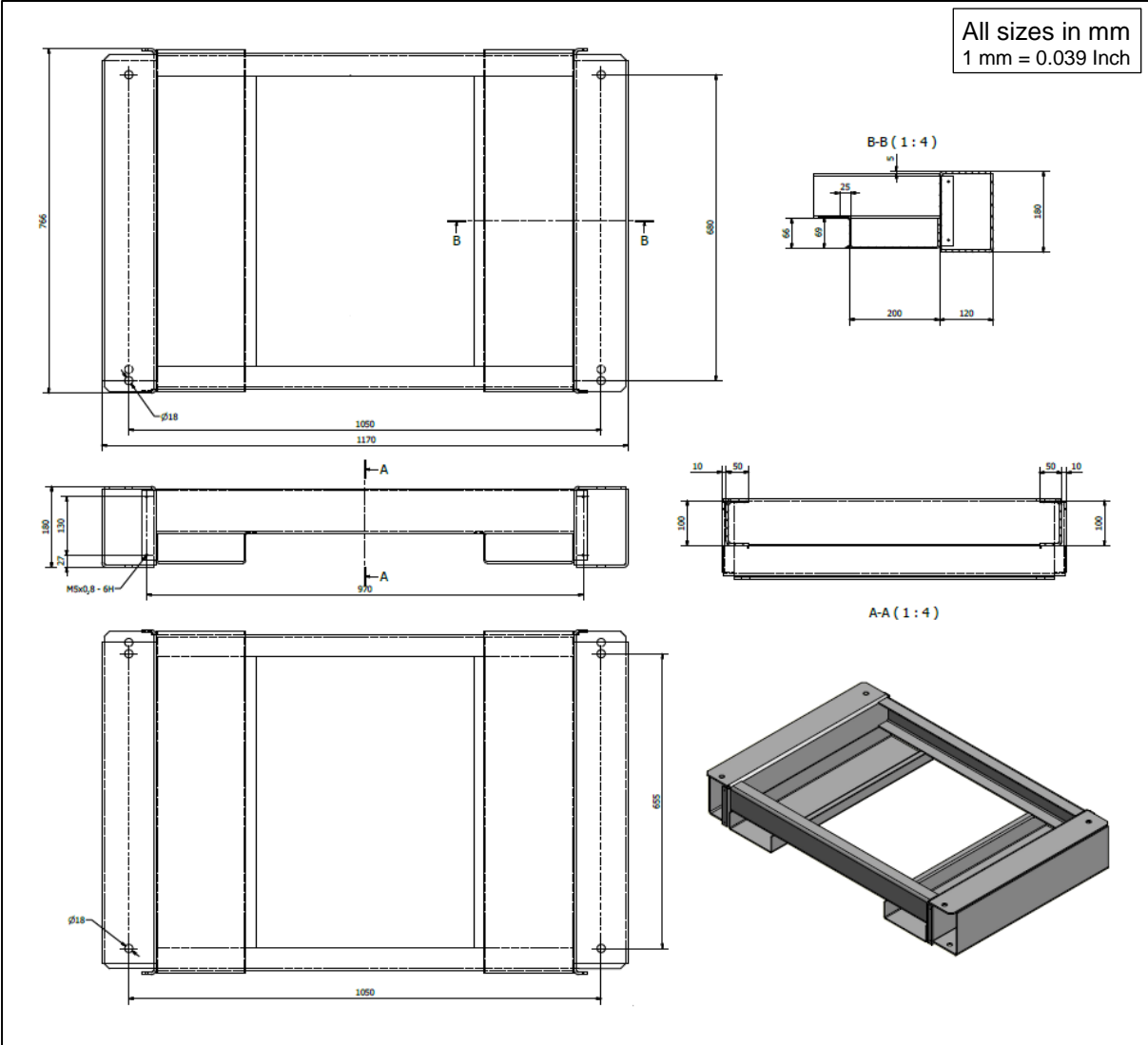

E. Power Cabinet – Outline with Foundation

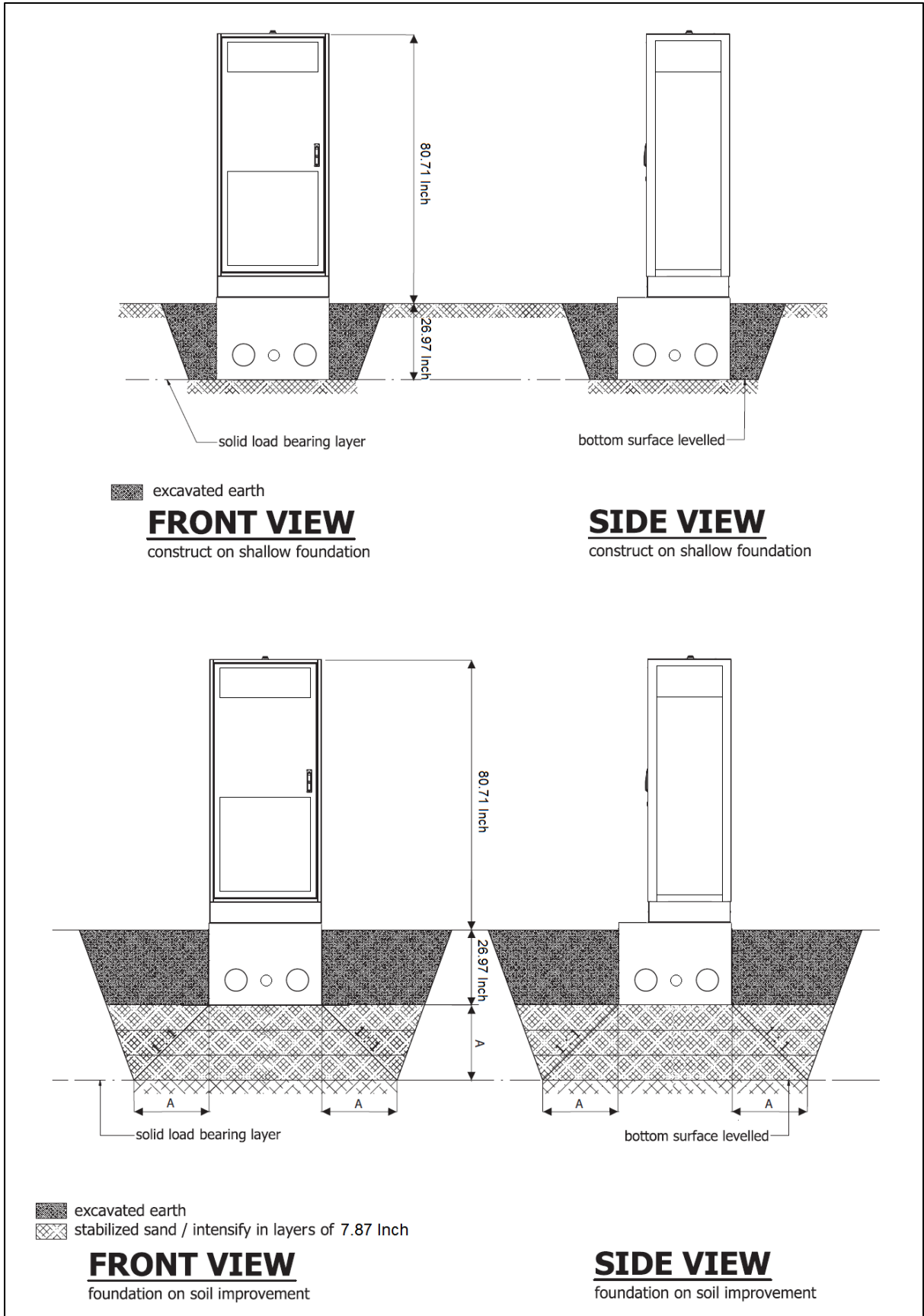

F. Signal connection diagram

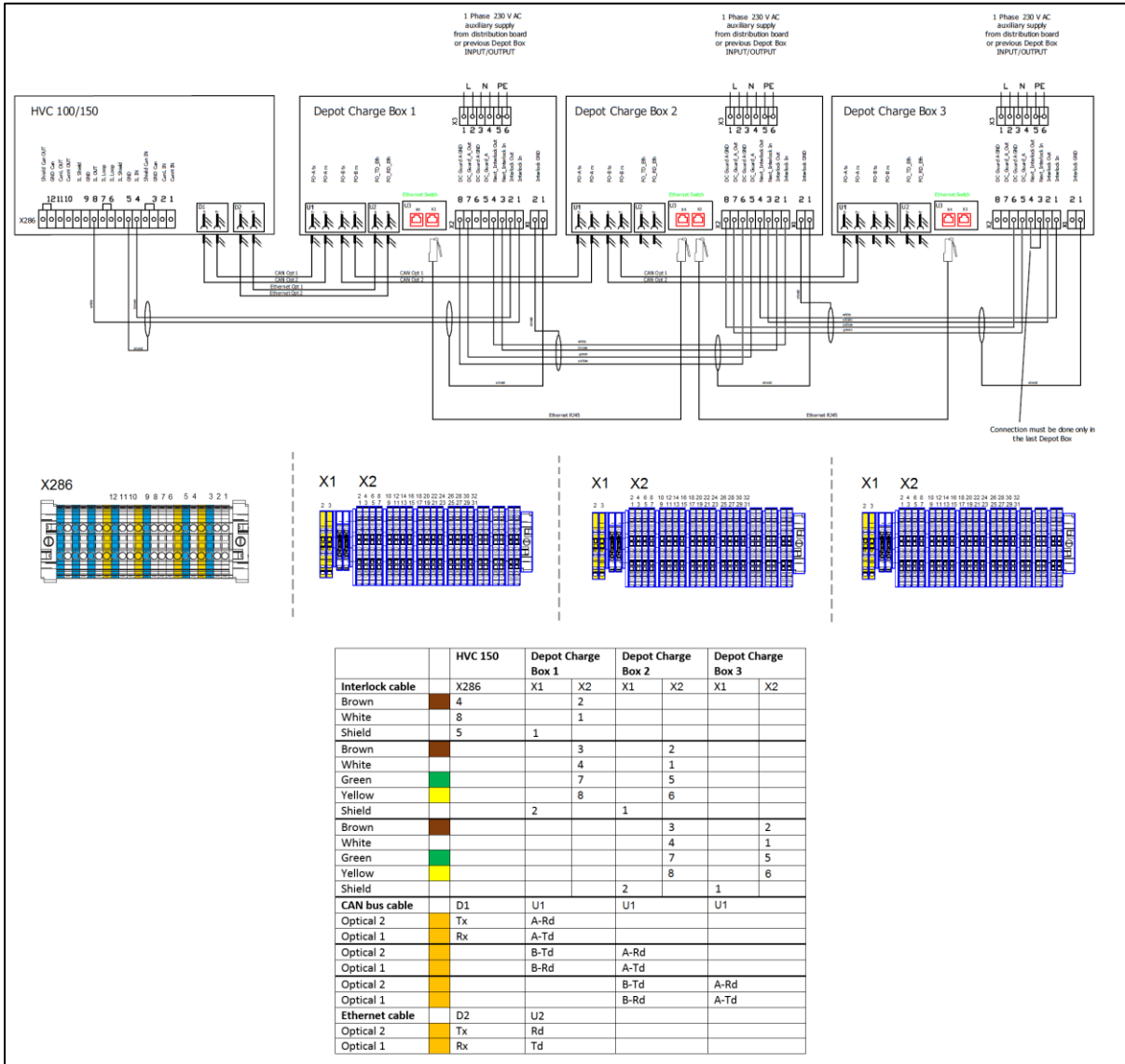

G. Ground overview of the system

